

105P

131986

TR-4-17-3-D  
August 19, 1963



FACILITY FORM 602

**N64-29523**

(ACCESSION NUMBER)

105

(PAGES)

SMX-51925

(NASA CR OR TMX OR AD NUMBER)

(THRU)

(CODE)

10

(CATEGORY)

**LIBRARY COPY**

OCT 3 1963

LANGLEY RESEARCH CENTER  
LIBRARY, NASA  
LANHAM, MARYLAND  
HAMPDEN

FUTURE STUDIES BRANCH  
ACTIVITIES REPORT  
FISCAL YEAR 1963

**OTS PRICE**

XEROX

\$

9.10 ph

MICROFILM

\$

\_\_\_\_\_

August 19, 1963

LAUNCH OPERATIONS CENTER

---

TR-4-17-3-D

---

FUTURE STUDIES BRANCH

ACTIVITIES REPORT

FISCAL YEAR 1963

ABSTRACT

The purpose of this report is to acquaint the individuals associated with this country's space program with the past, present, and planned future efforts of the Future Studies Branch, Launch Operations Center, National Aeronautics and Space Administration. Thus, it is intended for interested persons both within and outside U.S. Government agencies. Such an approach should provide industry with a more precise awareness of the Government's needs in the various space programs, and should promote cooperation and eliminate duplication of effort in concurrent programs being conducted by the various agencies.

As of July 1, 1962, Launch Operations officially became a Center on a level comparable to Marshall Space Flight Center. Under this new organization, the Future Launch Systems Study Office is now known as the Future Studies Branch, and is performing similar functions.

No attempt was made to indicate the detailed technical findings of the studies performed by this organization. Those persons interested in more detailed information on any specific topic discussed in this publication may obtain it from the Future Studies Branch (LO-DF). Follow-on reports of a similar nature to this one will be released.

LAUNCH OPERATIONS CENTER

---

TR-4-17-3-D

---

FUTURE STUDIES BRANCH

ACTIVITIES REPORT

FISCAL YEAR 1963

LAUNCH SUPPORT EQUIPMENT

ENGINEERING DIVISION

## TABLE OF CONTENTS

<u>Section</u>	<u>Page</u>
I INTRODUCTION	1
II LONG RANGE PLANNING DATA	3
III FUTURE STUDIES BRANCH MISSION	
A. General . . . . .	5
B. Mission . . . . .	5
C. Responsibilities . . . . .	5
D. Origination to Present Status . . . . .	6
IV FISCAL YEAR 1963 OPERATIONS	
A. Organizational Breakdown and Description . . . . .	9
B. Study Breakdown . . . . .	9
C. Man Hours Breakdown . . . . .	12
V COMPUTER UTILIZATION	
A. Need for Computer Assistance . . . . .	15
B. Completed Program Examples . . . . .	15
VI PERSONNEL	16
VII PUBLICATIONS	
A. General . . . . .	21
B. Fiscal Year 1963 Government Publications . . . . .	21
C. FY 1960, 1961, 1962 Government Publications . . . . .	23
D. Miscellaneous Publications and Presentations . . . . .	29
E. Selection of Available Major Contracted Study Reports . . . . .	31
VIII FISCAL YEAR 1963 IN-HOUSE STUDY PROGRAMS	
A. Lunar Logistics System . . . . .	37
B. Investigation of Checkout Procedures in Quality Assurance Division and Launch Operations Center . . . . .	37
C. Launch Probabilities . . . . .	37
D. Rift Program . . . . .	39
E. Lunar Tanker - SATURN V . . . . .	39
F. High Pressure Gas Storage - Earth . . . . .	39
G. High Pressure Gas Storage - Space . . . . .	39
H. Orbital Launch Facilities . . . . .	41



TABLE OF CONTENTS (Continued)

<u>Section</u>	<u>Page</u>
I. Complex 39 Launch Facilities . . . . .	41
J. Space Maintenance and Repair Committee . . . . .	41
K. NERVA Engine Review Committee. . . . .	41
L. Nuclear Safety and Hazards Working Group. . . . .	43
M. Launch Facility Requirements for Nuclear Stages. . . . .	43
N. Lightning Protection Systems for Future Space Vehicles, Launch Facilities and Ground Support Equipment. . . . .	43
O. Overwater Jet Impingement. . . . .	45
P. Facility Requirements due to Erosive Effects of Solid Pro- pellant Rocket Exhaust. . . . .	45
Q. Prediction of Object Motion in a Vacuum when Subjected to Rocket Engine Exhaust Gases . . . . .	45
 IX CURRENT IN-HOUSE STUDY PROGRAM	
A. Lunar Logistics System . . . . .	49
B. Contract Work Statements . . . . .	51
C. Advanced Orbital Launch Operations. . . . .	51
D. Exotic Propellant Facilities . . . . .	51
E. Supporting Technology and Advanced Studies Control Handbook. . . . .	53
F. High-Pressure Gas Storage. . . . .	53
G. Launch Facility Nuclear Safety . . . . .	53
H. Thermal Design of Launch Deflectors . . . . .	53
I. Overwater Jet Impingement . . . . .	55
 X LAUNCH OPERATIONS CENTER OUT-OF-HOUSE STUDY PROGRAMS, FISCAL YEAR 1963	
A. Launch Umbilical Tower (LUT) Connections at the Pad. . . . .	56
B. Metal Erosion of Solid Propellant Jets (SPREE). . . . .	56
C. Jet Impingement on Water . . . . .	58
D. Rescue and Escape Systems . . . . .	58
E. NOVA Launch Facility Study . . . . .	58
 XI LAUNCH OPERATIONS CENTER OUT-OF-HOUSE STUDY PROGRAMS, FISCAL YEAR 1964	
A. Facility Concepts for Large Thrust Vehicles. . . . .	60
B. Leak Detection Methods. . . . .	60
C. Reduction of LH <sub>2</sub> Boiloff Rates. . . . .	60
D. Helium Use and Reuse Techniques . . . . .	61
E. Advanced Launcher and Deflector Related Studies. . . . .	61

TABLE OF CONTENTS (Continued)

<u>Section</u>	<u>Page</u>
F. Special Launch Support Equipment and Facilities Required for Future Missions . . . . .	61
G. Cryogenic Propellant Storage and Transfer Techniques . . . . .	61
H. High Pressure-High Flow Rate Flexible Hoses and Couplings. . . . .	62
I. Improve Launch Site Assembly and Checkout Techniques. . . . .	62
J. Facilities for Solid Propellant Vehicles . . . . .	62
K. Launch Facilities for Orbital Operations . . . . .	62
<b>XII SELECTIONS FROM THE PLANNED STUDY PROGRAMS, FISCAL YEAR 1965 AND BEYOND</b>	
A. Special Solid Propellants Hazards Analysis . . . . .	63
B. Launch Probability Analysis . . . . .	63
C. High-Pressure Gas Storage, Transfer, and Utilization Techniques. . . . .	63
D. Reduction of Vehicle and GSE Electrical and Mechanical Tolerances . . . . .	63
E. Firing Accessories and Umbilical Concepts . . . . .	64
F. Alternate Launch Site Studies . . . . .	64
G. Investigation of Initial Orbital Launching Facilities . . . . .	64
H. Integration of Special Nuclear Stage Requirements on Launch Facility and Operational Plans . . . . .	64
I. Facility Requirements For Recoverable Boosters . . . . .	64
J. Feasibility of Offshore Launch Facilities For Large Vehicles. . . . .	65
K. Communications and TV Camera Control System Study . . . . .	65
L. Service Structure Concepts Study . . . . .	65
<b>XIII SELECTIONS FROM PAST STUDY EFFORTS FISCAL YEARS 1960, 1961, and 1962</b>	
A. Proposed Launch Facilities Studies . . . . .	67
B. Ground Support Equipment Studies . . . . .	69
C. Orbital and Lunar Operational Studies . . . . .	73
D. Launch Vehicle Studies . . . . .	86
E. Miscellaneous Studies . . . . .	86
<b>XIV CURRENT SUPPORT ON MFSC-CONTRACTED STUDIES</b>	
A. NOVA Vehicle Systems Studies . . . . .	89
B. Post-NOVA Launch Vehicle Study . . . . .	89
C. Ten-Ton Reusable Booster . . . . .	89
D. Reusable Ground Launch Vehicle, 50- to 100-Ton Orbital Payload Class . . . . .	90

TABLE OF CONTENTS (Continued)

<u>Section</u>	<u>Page</u>
E. Advanced Lunar Transportation . . . . .	90
F. Cryogenic Insulation Integration . . . . .	90
G. Nuclear Lunar Logistics System . . . . .	90
H. Nuclear Flight Safety Study . . . . .	90
I. Early Manned Interplanetary Missions . . . . .	90
J. Manned Mars Exploration in the Unfavorable Time Period . . . . .	92
K. Fluid Transfer at Low "G" . . . . .	92
L. Solids Safety Handbook Study . . . . .	92
M. Cost Model for Launch Vehicle . . . . .	93
 APPROVAL	 94
 DISTRIBUTION	 95

## LIST OF ILLUSTRATIONS

<u>Number</u>	<u>Title</u>	<u>Page</u>
1.	SATURN Launch Facility (1960) . . . . .	2
2.	Launch Operations Center Missions . . . . .	4
3.	Launch Support Equipment Engineering Division Organization . . .	8
4.	Future Studies Branch - Major Areas of Contact . . . . .	10
5.	Future Studies Branch - Functional Organization . . . . .	11
6.	Future Studies Branch Personnel . . . . .	13
7.	Future Studies Branch Manpower Distribution, Fiscal Year 1963	14
8.	Lightning Striking the George Washington Monument . . . . .	22
9.	Launch Complex 37 Deflector . . . . .	24
10.	SATURN Launcher, VLF-37 . . . . .	26
11.	SATURN Offshore Launch Facility . . . . .	28
12.	Lunar Propellant Depot . . . . .	30
13.	SATURN Launch Facility . . . . .	32
14.	SATURN Mobile Launcher/Transporter-Rail Concept . . . . .	34
15.	NOVA Stage Checkout Area . . . . .	35
16.	2,500-Pound Lunar Roving Vehicle . . . . .	36
17.	SATURN Crawler . . . . .	38
18.	Orbiting Scientific Laboratory . . . . .	40
19.	Launch Complex 39, Pad Area Concept . . . . .	42
20.	Launcher/Umbilical Tower at Refurbishment Area . . . . .	44
21.	Exterior View of 10,000-Pound Lunar Roving Vehicle . . . . .	47
22.	Interior View of 10,000-Pound Lunar Roving Vehicle . . . . .	48
23.	Artist's Concept of a 10,000-Pound Lunar Roving Vehicle . . . .	50
24.	Lunar Excursion Module with the Lunar Roving Vehicle . . . . .	52
25.	Lunar Excursion Module with the Lunar Roving Vehicle on the Lunar Surface . . . . .	54
26.	NOVA Pad Area with Launch Building . . . . .	57
27.	NOVA Launch Building . . . . .	59
28.	Launch Complex 39 Concept . . . . .	66
29.	SATURN Mobile Launcher/Transporter-Barge . . . . .	70
30.	Artist's Concept of Launch Complex 39 Crawler . . . . .	71
31.	Artist's Concept of a Pad for Launch Complex 39 . . . . .	74
32.	Orbital Propellant Depot . . . . .	76
33.	Cryogenic Propellant Tankers . . . . .	78
34.	Refueling Operations in Orbit . . . . .	80
35.	Liquid Oxygen Space Tanker, 200,000-Pound Capacity . . . . .	83
36.	Orbital Propellant Tank with Shadow Shields . . . . .	84
37.	Orbital Propellant Tanks Orientation . . . . .	85
38.	NOVA Engine Checkout Area . . . . .	88
39.	NOVA Vertical Assembly Building . . . . .	91

## SECTION I INTRODUCTION

For the third consecutive year, the Future Studies Branch of the Launch Operations Center is publishing a progress report on its past, present, and future missions and activities. The purpose of this report is to fulfill the necessary requirements of communicating with the great number of organizational segments and agencies about the numerous areas of research and development, in order to establish and maintain contact, flow of information, and coordination.

Thus, trends of future developments can be recognized, and study programs in the area of launch facilities, operations, and equipment can be planned ahead of time so that useful approaches are available when required.

Advanced study activity on space vehicle launch operations touches many related fields of engineering and science. A major effort is being carried on to keep up to date with the current technical "information explosion." This is accomplished by a constant scanning of new literature, close liaison with industry, and extensive participation in postgraduate university and Government courses.

To be of maximum possible effectiveness, a study group should be limited in size. This calls for effective manpower utilization. The electronic computer has been used as a major problem-solving tool. Thus, personnel are freed for more creative work.

Advanced studies begin with in-house work. The required range and scope of work are often extended by out-of-house contracts. The main effort is placed on originality of work. If necessary, close liaison is kept with related study efforts elsewhere.

The assistance given to this Branch in their study efforts by the other segments of the Launch Operations Center, the Marshall Space Flight Center, and various Offices of the NASA Headquarters is greatly appreciated.

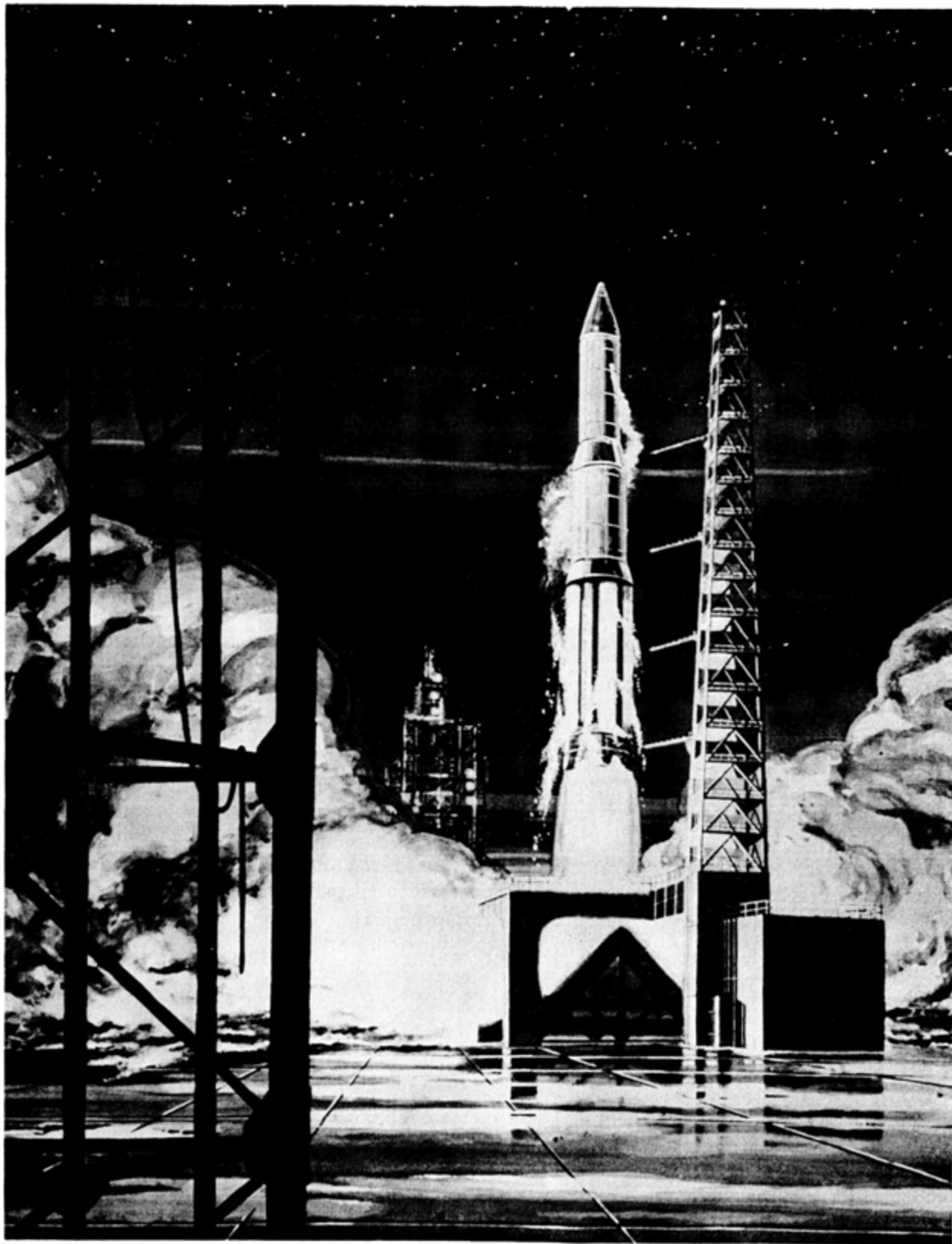

FIGURE 1. SATURN LAUNCH FACILITY (1960) (ARTIST'S CONCEPT)

## SECTION II LONG RANGE PLANNING DATA

In addition to the current heavy workload in planning, designing, and constructing large space vehicle launch facilities, and carrying on the intricate task of launch operations, the Launch Operations Center is involved in a substantial effort in the areas of Supporting Technology and Advanced Studies. These efforts form the basis for all future-facility planning. Future-facility planning is accomplished by LOC managed studies performed in parallel and concurrently with future-space-vehicle studies within NASA, particularly within Marshall Space Flight Center (MSFC).

The table below shows, in general terms, areas where advanced thinking of LOC is concentrated. Included are direct facility studies, supporting technology, advanced studies, and areas of study which are a direct outgrowth of in-house work by LOC; that is, extraterrestrial propellant storage and surface transportation.

Table 1. Long Range Planning Data

Fiscal Year	63	64	65	66-70	70-75
<b>Launch Facilities</b>					
1. NOVA	██████████				██████████
2. Post-NOVA	██████████				██████████
3. Horizontal Launch	██████████				██████████
4. Solid Stage			██████████		
5. Nuclear Stage	██████████				
6. Electrical Stage		██████████			
7. Foreign	██████████				
8. Site Survey	██████████				
<b>Supporting Research</b>					
1. Supporting Technology	██████████				
2. Advanced Studies	██████████				
3. Launch Operations Analysis (including orbital and lunar)	██████████				
4. Propellant Storage (including extraterrestrial)	██████████				
5. Surface Transportation (including planetary)	██████████				

Supporting

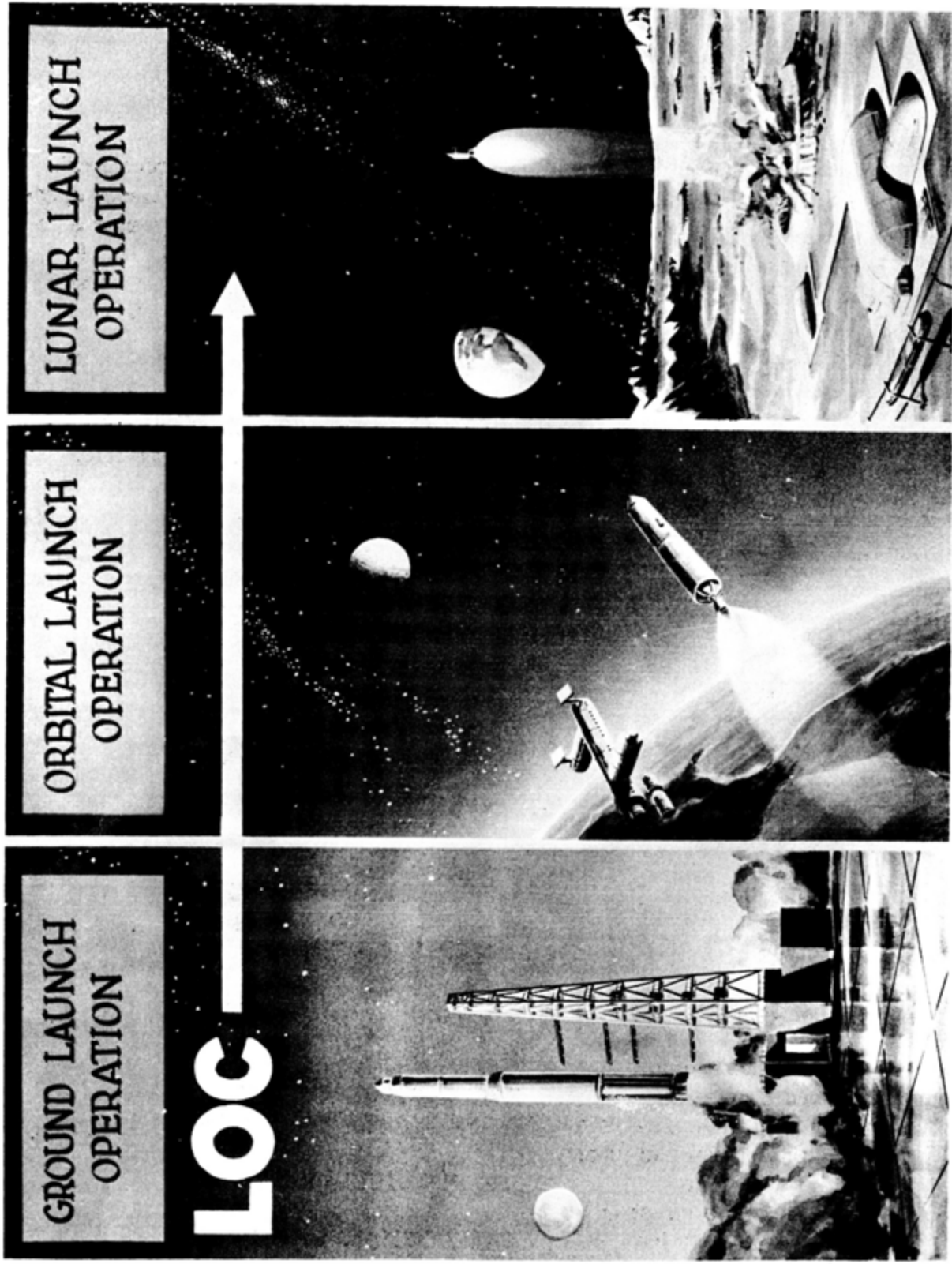

FIGURE 2. LAUNCH OPERATIONS CENTER MISSIONS



## SECTION III FUTURE STUDIES BRANCH MISSION

### A. GENERAL.

As man extends himself farther beyond the earth, the scope and extent of his operations, both in space and at the launch site, become increasingly large and complex. The task of supporting America's lunar program requires tremendous ground facilities, far advanced beyond anything that has been previously used.

The Launch Operations Center, under the direction of Dr. Kurt Debus, is responsible for providing all launch facilities and ground support equipment to launch any space vehicle and payload that may be required for the lunar and other programs.

The Future Studies Branch of LOC is responsible for providing concepts and preliminary design guidelines for future launch facilities and support equipment.

### B. MISSION.

The Future Studies Branch mission is:

1. To study future launch vehicle system missions, and determine and present, through preliminary drawings, calculations, and reports, the major items and phases required to achieve full compatibility of space and ground support equipment and space vehicle for insurance of success of the overall missions and programs.

2. To provide the vehicle and support equipment designers, both ground oriented and space oriented, guidelines and operational philosophies to assure the office chiefs that all facets of the programs are adequately supported.

3. To support other NASA Centers with engineering design studies and system integration capabilities as required to fulfill current and future programs.

4. To provide, through presentations and reports, the Center with the latest industry developments that may be applicable to current and future programs.

### C. RESPONSIBILITIES.

Future Studies work also includes the following:

1. Investigates, analyzes, evaluates, and determines optimum facilities and layouts for future-vehicle ground launch systems.

2. Performs operational, logistic, and cost investigations for feasibility studies on all types of ground launch vehicle systems.

3. Studies new recovery techniques for small components and large winged structures, and recommends the most desirable method for inclusion into present and future launch facilities.

4. Evaluates requirements and determines optimum vehicle and launch systems for extraterrestrial explorations.

5. Investigates and determines systems engineering concepts of space launched vehicles with respect to facilities and operating requirements.

6. Performs feasibility and design studies, and analytical investigations in the preparation of technical proposals for facilities and logistics for future space flight launch systems.

7. Performs operational, logistic, and cost investigations for feasibility studies on all types of future space flight vehicle systems.

8. Performs feasibility and design studies for support of space cryogenic storage, space vehicle maintenance, and space vehicle launching.

9. Determines and performs preliminary design of special ground support equipment and space support equipment required for specific space launchings.

#### D. ORIGINATION TO PRESENT STATUS.

Future Studies work began in 1959 before NASA's George C. Marshall Space Flight Center (MSFC) was established. Then, under the Future Launch Systems Office, the group performed the long range planning and preliminary design for launch facilities and ground support equipment for the SATURN vehicle.

As NASA's manned space program matured, preliminary investigations of orbital operations, such as rendezvous, orbital launch, and orbital storage of cryogenics, were conducted. From them came much of the knowledge and direction of our present manned flight program.

In July, 1962, Launch Operations became a separate and distinct NASA Center. At the same time, the lunar program was gaining impetus under President Kennedy's directive setting the manned lunar landing as a national goal.

Now, it also became the task of the Future Studies Branch to act as a liaison, between MSFC and LOC. The stringent requirements of the lunar program made it necessary to design vehicle facilities and GSE as a single, integrated system. To this end, the Branch was involved in the initial formulation of Launch Complex 39.

This Complex would have to provide logistic support for the lunar program. Such support includes rescue capability and base establishment. Thus, a high launch rate was required.

The concepts evolved for LC-39 were significant advances in launch technology, and have given LOC the technology for handling even larger launch vehicles, such as NOVA.

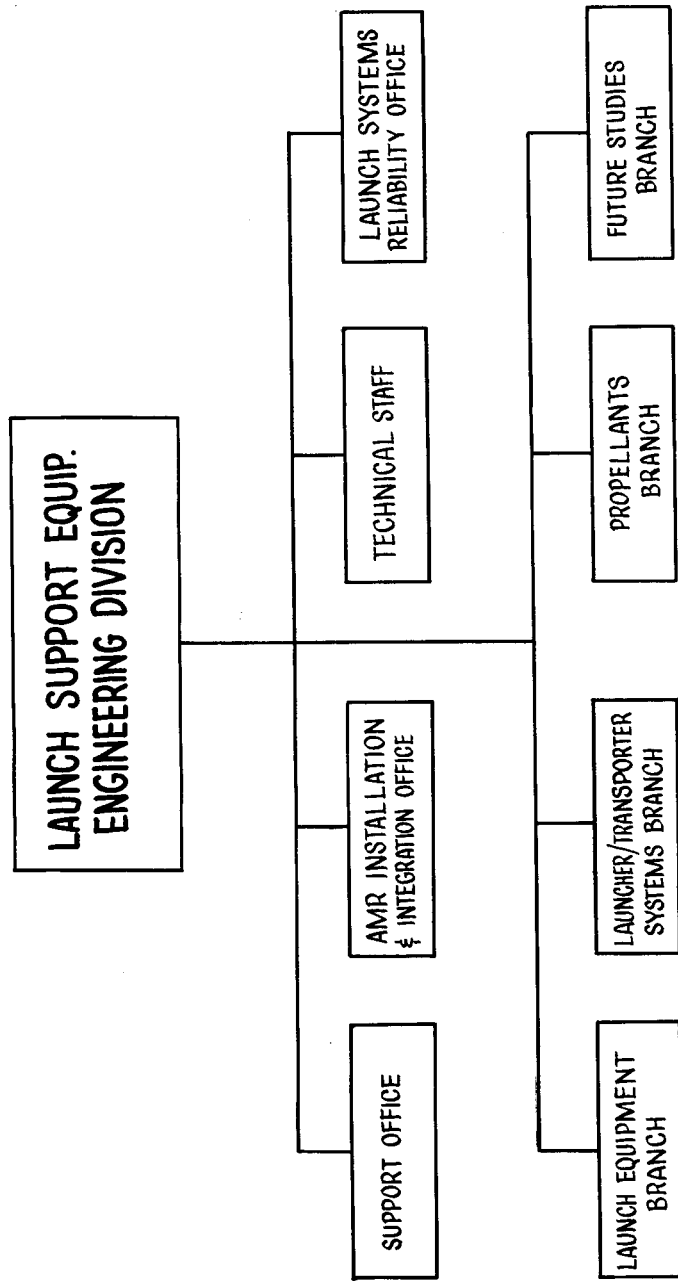

FIGURE 3. LAUNCH SUPPORT EQUIPMENT ENGINEERING DIVISION ORGANIZATION

SECTION IV  
FISCAL YEAR 1963 OPERATIONS

A. ORGANIZATIONAL BREAKDOWN AND DESCRIPTION.

The Future Studies Branch is organizationally one of eight subordinate groups within the Launch Support Equipment Engineering Division of Launch Operations Center. The Branch functionally supports the work of all divisions in LOC and, in special cases, performs supporting work for certain divisions of the Marshall Space Flight Center and the Office of Manned Space Flight Groups where such support also benefits LOC. Figure 4 sketches the major areas of contact that have been experienced by the Branch in pursuit of its missions.

The internal functional organization of the Future Studies Branch is outlined in figure 5. The two sections, Ground Launch and Space Launch, are further broken down into compartments of more specific areas of responsibility. Flexibility of operation is gained by not holding the efforts of the individual project engineers rigidly within their prime area of responsibility. A staff function has been established to utilize personnel with special abilities as consultants in the various areas of study work.

The Branch has grown from two to fourteen people in four years to meet the increasing demands for its services. The growth is expected to level out with a total of eighteen personnel, at the end of FY 64. This relatively compact group, with improving methods, is expected to meet all foreseeable workloads and still maintain efficient and effective operation (see figure 6).

B. STUDY BREAKDOWN.

The work of this branch can be roughly classified into three somewhat overlapping categories.

1. In-House Engineering Studies. The in-house studies can have results in the form of formal published Government reports, through simple memorandum reports, to a file of notes. The majority of the in-house studies precede, supplement, or are a corollary to contracted studies and assist in writing effective contract work statements, in-progress guidelines, and final study evaluation.

2. Contracted or Out-of-House Engineering Studies. The out-of-house studies, placed with various national concerns, result in formal reports detailing contractor efforts with appropriate data, discoveries, procedures, etc.

3. Technical Support Activities.

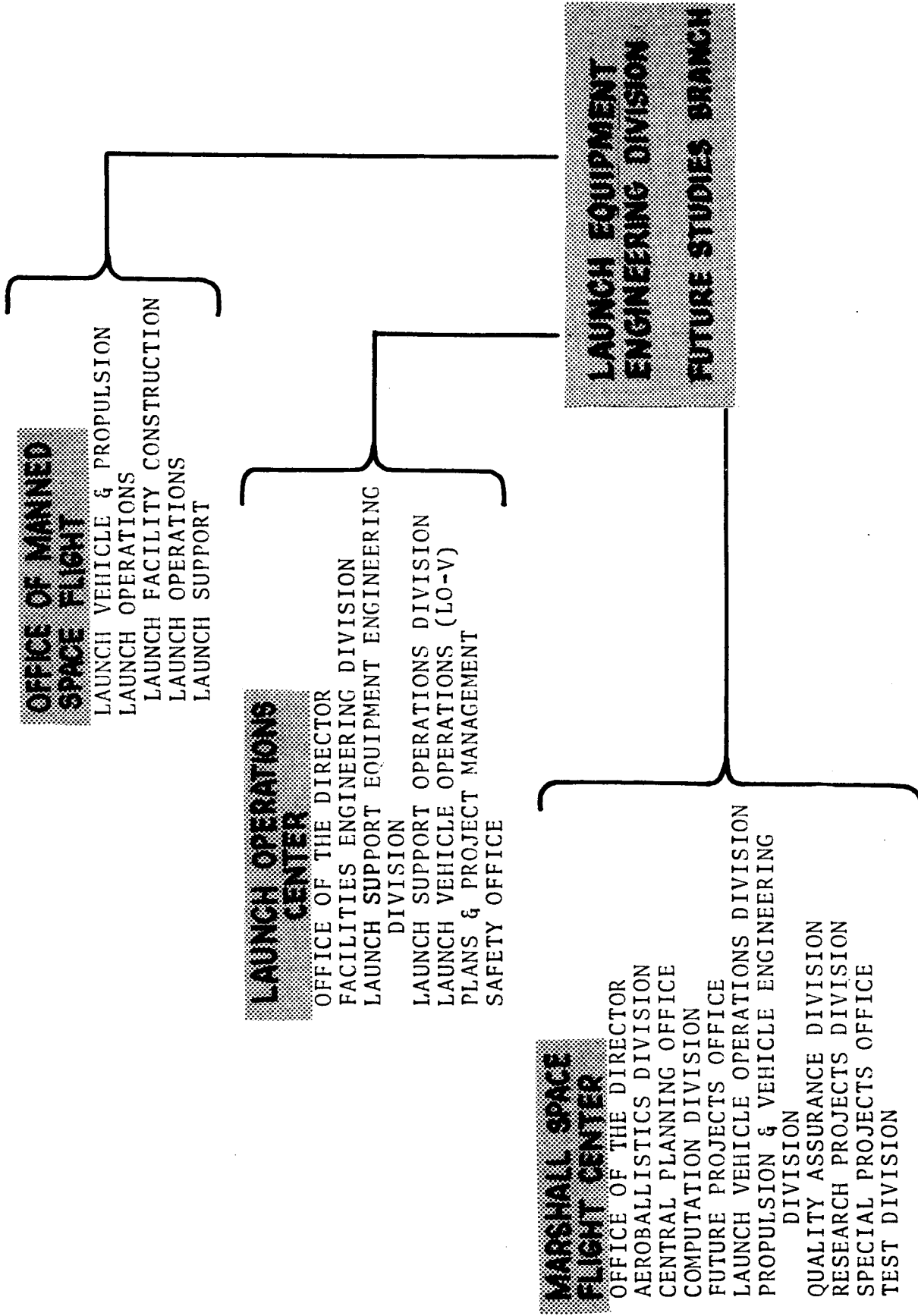

FIGURE 4. FUTURE STUDIES BRANCH - MAJOR AREAS OF CONTACT

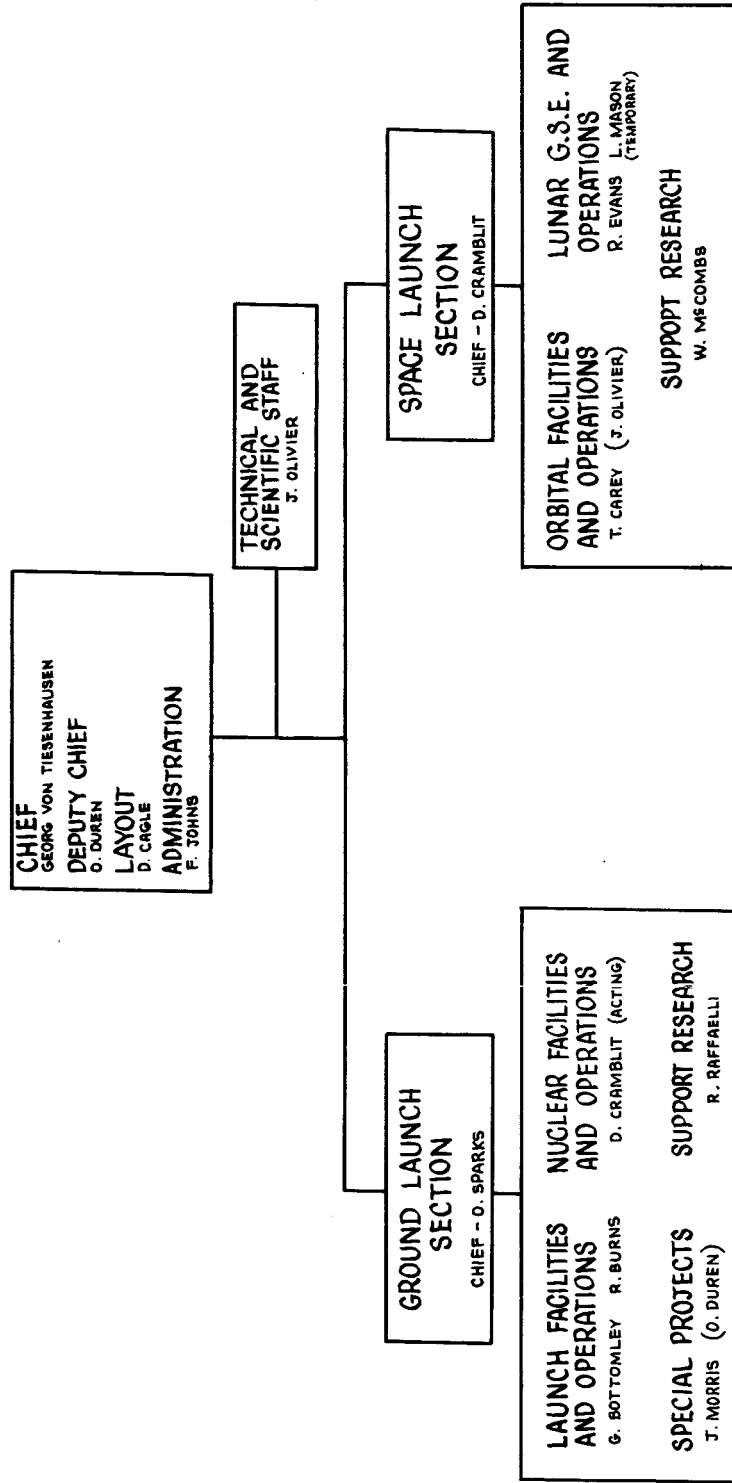

FIGURE 5. FUTURE STUDIES BRANCH - FUNCTIONAL ORGANIZATION

### C. MAN-HOURS BREAKDOWN.

In Fiscal Year 1963 the Future Studies Branch averaged twelve personnel amounting to 24,000 man-hours of in-house effort. Branch personnel guided and supervised some 37,000 man-hours of LOC contract studies and 25,000 man-hours of MSFC studies as detailed in the following table.

Table 2. FY 1963 Man-Hour Distribution

Center	Category	In-House Man-Hours	LOC Contracts	MSFC Contracts	Total Man-Hours
LOC	Supporting Technology and Advanced Studies	15,400	37,400	--	52,800
	Administration and Staff	4,000	--	--	--
MSFC SUPPORT	FPO	1,000	--	17,500	18,500
	SPA	500	--	--	500
	AERO	1,000	--	--	1,000
	P&VE	100	--	7,500	7,600
	RPD	2,000	--	--	2,000
TOTALS		24,000	37,400	25,000	86,400

Figure 7 details the FY 1963 percentage distribution of the Branch manpower for in-house efforts, and a similar distribution of total study manpower (in-house and contracted) under the responsibility of the Branch Chief.

Briefly, 19 percent of the in-house manpower is utilized in supporting MSFC functions. Considering total manpower, which includes LOC and MSFC contracted manhours, 34-1/2 percent directly benefits MSFC with a significant proportion of this percentage indirectly benefiting LOC. The bulk of the total manpower, 65-1/2 percent directly benefits the Launch Operations Center.

It is expected that this dual support role of the Future Studies Branch will continue to the benefit of both Centers.



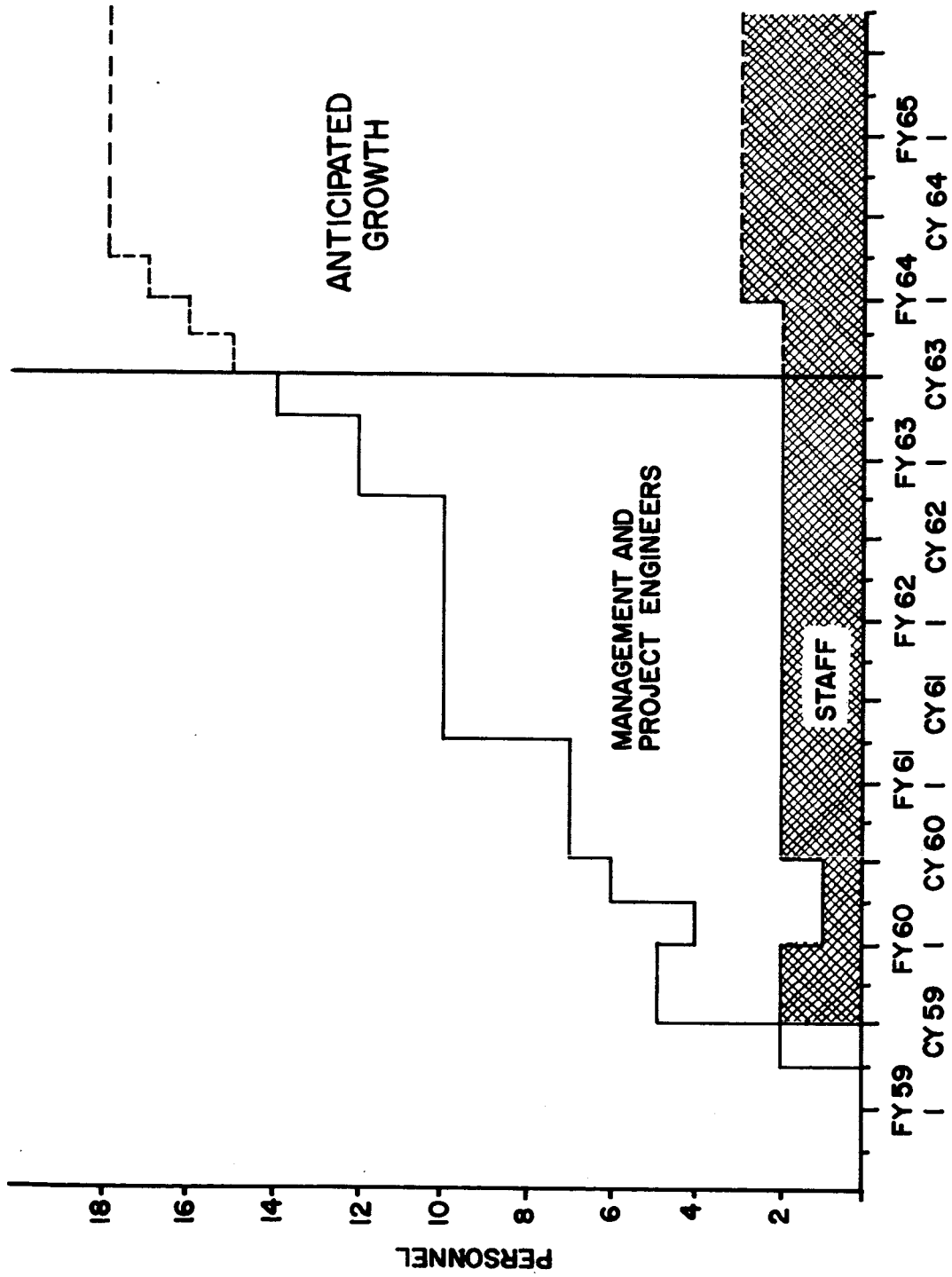

FIGURE 6. FUTURE STUDIES BRANCH PERSONNEL

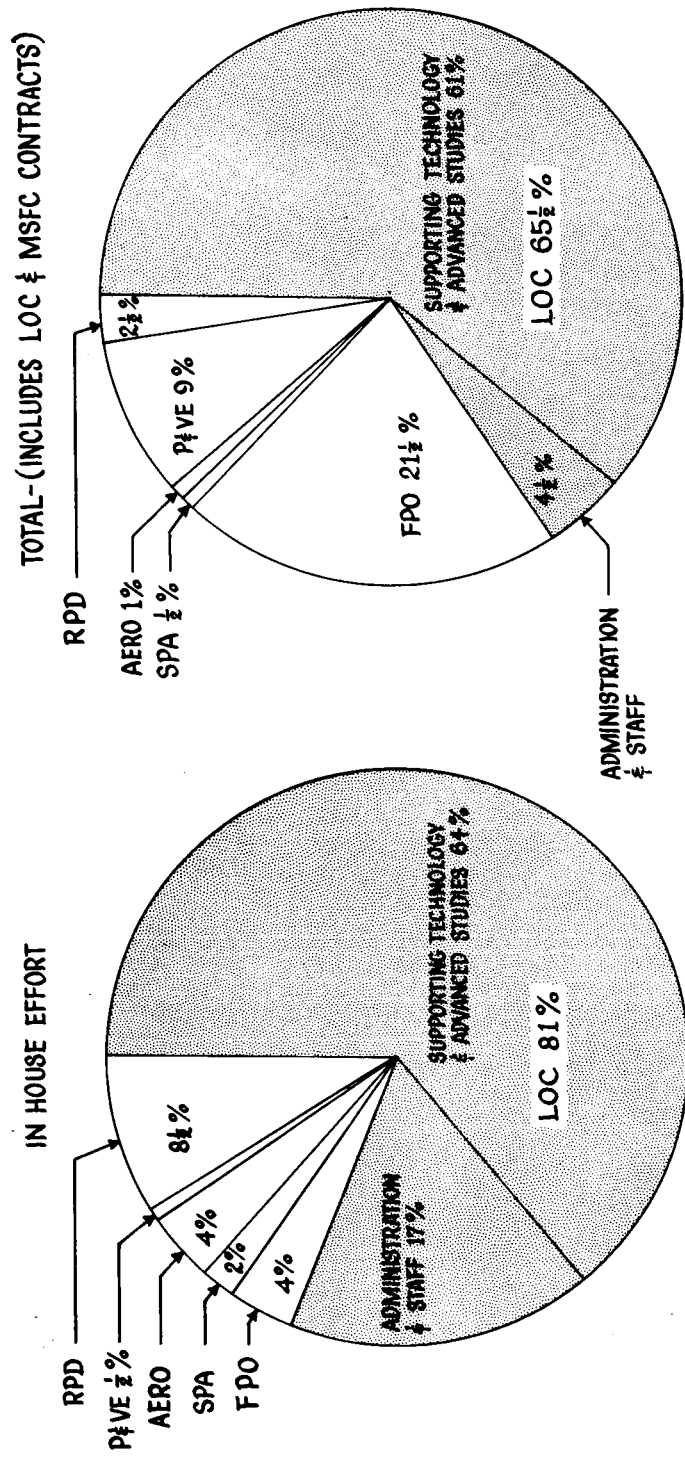

FIGURE 7. FUTURE STUDIES BRANCH MANPOWER DISTRIBUTION, FISCAL YEAR 1963

## SECTION V COMPUTER UTILIZATION

### A. NEED FOR COMPUTER ASSISTANCE.

The workload within LOC has been steadily increasing as greater efforts are applied to the space program to reach the moon in this decade. The effect upon the Future Studies Branch as the program matures has been pronounced. During the past year, it became clear that additional measures were needed to permit personnel to efficiently apply their efforts to a wide variety of technical subjects.

Arrangements were made for key personnel to attend courses to receive training for operating several computer facilities of other divisions. As these personnel became qualified, they demonstrated the effectiveness of computers for study applications. It was determined that LO-D Division required a computer facility of its own. In the near future it is anticipated that an IBM 1620, Model II, 40K machine with an on-line printer will be available.

### B. COMPLETED PROGRAM EXAMPLES.

To date a number of programs has been successfully completed. The following programs are representative of these efforts.

1. Heat Transfer to Launch Deflectors. A program to establish the temperature distribution in a flat plate as a function of time has been completed. This program, which accounts for the change in thermal conductivity and diffusivity in 1020 carbon steel plate, will be used in conjunction with future test programs to determine heat transfer coefficients associated with engine exhaust jet streams.

2. Lunar Storage of Cryogenic Hydrogen. Two programs have been written to determine the feasibility of long-term storage of cryogenic hydrogen on the lunar surface. These programs consider both spherical and cylindrical configurations and permit the design parameters involved to be investigated over a wide range.

As additional personnel are trained to operate computers, it is anticipated that the Future Studies Branch will be able to handle up to a 50 percent larger workload.

SECTION VI  
PERSONNEL

MANAGEMENT AND STAFF

LO-DF  
539-0641

CHIEF:

Mr. Georg von Tiesenhausen, BSME  
Hamburg Technical College, Germany, 1943

Major Areas of Effort: Ground and space launch study program management, conceptual design, and new and unique approaches to current and future ground support equipment and facility requirements.

DEPUTY CHIEF:

Mr. Olin K. Duren, BSME  
Auburn University, 1951

Major areas of Effort: Assist in overall study program planning and control, launch facilities and ground support equipment design, operational modes analysis, cost analysis, and procurement.

CONCEPTUAL DESIGNER/ILLUSTRATOR:

Mr. E. D. Cagle, Diploma, Graphic Arts  
Gulf States Art School, 1953

Major Areas of Effort: Conceptual design and illustration of ground, orbital, and launch facilities and ground support equipment.

SECRETARY:

Mrs. Fay H. Johns  
Larimore Business College, 1945

SCIENTIFIC AND TECHNICAL STAFF

STAFF ENGINEER:

Mr. J. R. Olivier, BSME, MAE  
Mississippi State University, 1956  
Chrysler Institute, 1958

Major Areas of Effort: Conceptual design of orbital launch facilities, cryogenic

storage tankers, orbital and rendezvous operational techniques, and theoretical analysis of problems associated with the development of ground support equipment and facilities for space and lunar applications, and specialized mobile equipment.

**Publications:**

Contributor to United States Army Project Horizon  
Orbital Refueling - A Feasibility Study and Design Concept - PHASE I  
and PHASE II  
Orbital Storage of Liquid Hydrogen  
Lunar Storage of Liquid Propellants  
Ground Facility Requirements for Subcooling Liquid Hydrogen  
Proposal for Determining the Mass of Liquid Propellant within a Space  
Vehicle Propellant Tank Subjected to Zero Gravity Environment  
Orbital Launch Facility  
First Progress Report Lunar Trafficability Study  
Lunar Surface Mobility  
Launch Probability of Future Space Vehicles (SECRET)  
Contributor to Lunar Logistics System Mobility on the Lunar Surface and  
Payloads

**GROUND LAUNCH SECTION**

LO-DFG  
539-0642

**SECTION CHIEF:**

Mr. Owen L. Sparks, BSME  
Auburn University, 1939

**Major Areas of Effort:** Launch facilities study program definition and management, overall programming and scheduling of large and solid propellant vehicles and launch facilities, acoustics, and future facility developments.

**Publications:**

Development Proposal for a 24-Hour Communications Satellite System  
Ground Support Equipment  
Lunar Soft Landing Study  
Proposed Test Facility for Ground Test of Space Support Equipment  
A Lunar Subsurface Sampling Device  
Preliminary Concepts of Launch Facilities for Manned Lunar Landing  
Program  
Offshore Launch Facility Study  
Launch Deflector Criteria and their Application to the SATURN C-1 De-  
flector

**PROJECT ENGINEER:**

Mr. J. W. Morris, Jr., BSME  
Auburn University, 1956

Major Areas of Effort: Evaluation and coordination of launch facility studies and program; investigates specialized ground support equipment items for future facilities requirements.

**PROJECT ENGINEER:**

Mr. A. R. Raffaelli, BME, BIE  
University of Florida, 1958

Major Areas of Effort: Coordination and control techniques of ground and space launch program studies, propellant and gas facilities, and future launch facility safety.

Publications:

Introduction to Lightning  
Study Control Handbook

**PROJECT ENGINEER:**

Mr. R. T. Burns, BSCE  
Kansas State University, 1959

Major Areas of Effort: Structural design and analysis of future earth and extraterrestrial facilities, checkout and launch operations.

Publications:

An Operational Analysis of the SATURN SA-3 Vehicle from Static Firing to Launch.

SPACE LAUNCH SECTION

LO-DFS  
539-0643

**SECTION CHIEF:**

Mr. David C. Cramblit, BSME  
University of Dayton, 1957

Major Areas of Effort: Conceptual design and analysis of facilities and ground support equipment supporting lunar and interplanetary missions, orbital and rendezvous techniques, management of studies relating to space environment and associated hazards to space travel, and lunar application, nuclear launch facilities.

**Publications:**

Radiation Hazards Associated with the Testing and Launch of a Nuclear Space Vehicle  
A Consideration of Lunar Surface Ballistics and the Hazards Associated with Spacecraft Landing or Return Operations  
First Progress Report, Lunar Trafficability Study  
Annual Activity Report, FY-62 - Future Studies Branch  
Lunar Surface Mobility  
A Consideration of Lunar Surface Ballistics and the Hazards Associated with Spacecraft Landing or Launch Operations  
Contributor to Lunar Logistics System Mobility on the Lunar Surface, and Payloads

**PROJECT ENGINEER:**

Mr. W. T. Carey, Jr., BME  
George Washington University, 1960

Major Areas of Effort: Countdown and checkout of future space vehicles, investigation of specialized equipment, maintenance, assembly.

**PROJECT ENGINEER:**

Mr. R. L. Evans, BSME  
Northeastern University, 1955

Major Areas of Effort: Lunar and space storage of cryogenics, jet stream and flame deflection analysis, insulation techniques, and other space-related projects in the fields of heat transfer, thermodynamics, analytical mathematics and fluid mechanics, launch probability analysis.

**Publications:**

Flame Deflector Configurations Required for the Attenuation of Exhaust Jets from C-5, C-4, C-4N, and NOVA Space Vehicle Boosters  
Lunar Storage of Liquid Propellants  
Launch Deflector Criteria and their Applications to the SATURN C-1 Deflector  
Proposal for Determining the Mass of Liquid Propellant Within a Space Vehicle Propellant Tank Subjected to Zero Gravity Environment  
The Launch Probability of Space Vehicles Within a Given Launch Window Planning Data for C-5 and NOVA Launch Facilities (SECRET)  
Launch Probability of Future Space Vehicles (SECRET)  
Contributor to Lunar Logistics System, Mobility on the Lunar Surface, and Payloads

PROJECT ENGINEER:

Mr. W. M. McCombs, BME  
Auburn University, 1962

Major Areas of Effort: Extraterrestrial support equipment concepts, mobility, heat transfer, power requirements

Publications:

Contributor to Lunar Logistics System, Mobility on the Lunar Surface, and Payloads

Throughout FY 1963, Branch personnel attended various technical seminars, Government and industry given and sponsored special courses, and postgraduate courses at the University of Alabama Center in Huntsville. The Branch project engineers are averaging at least one postgraduate course per man, per year.



## SECTION VII PUBLICATIONS

### A. GENERAL.

The publications prepared and released by the Future Studies Branch are listed in this section. They are grouped under the following categories:

- Fiscal Year 1963 Government Publications
- Fiscal Years 1960, 1961, and 1962 Government Publications
- Miscellaneous Publications and Presentations
- Selections of Available Major Contracted Study Reports

### B. FISCAL YEAR 1963 GOVERNMENT PUBLICATIONS.

<u>Title and Author</u>	<u>Date</u>	<u>Report No.</u>
Lunar Storage of Liquid Propellants, W. E. Dempster, R. L. Evans, and J. R. Olivier	July 1962	NASA TN D-1117
Ground Facility Requirement for Subcooling Liquid Hydrogen, W. E. Dempster, and J. R. Olivier	July 1962	NASA TN D-1276
First Progress Report Lunar Trafficability Study, G. von Tiesenhausen, J. R. Olivier, and D. C. Cramblit	September 1962	---
Annual Activity Report - FY 1962 Past, Present, and Future Projects, D. C. Cramblit	September 1962	---
Preliminary Presentation Notes Lunar Trafficability Study, G. von Tiesenhausen	November 1962	---
Summary of Launch Complex 39, O. K. Duren	November 1962	LTIR-2-DF-62-4
Lunar Surface Mobility, J. R. Olivier and D. C. Cramblit	December 1962	LTIR-2-DF-62-5
Introduction to Lightning, A. R. Raffaelli	December 1962	LTIR-2-DF-62-6



FIGURE 8. LIGHTNING STRIKING THE GEORGE WASHINGTON MONUMENT

<u>Title and Author</u>	<u>Date</u>	<u>Report No.</u>
Space Vehicle Launch Operations Analysis and Predictions Vol II of II, Launch Probability of Future Space Vehicles (SECRET), R. L. Evans and J. R. Olivier	February 1963	LIN-DF-63-1
A Consideration of Lunar Surface Ballistics and the Hazards Associated with Spacecraft Landing or Launch Operations, D. C. Cramblit	March 1963	NASA TN D-1526
Major Contributor to Vol. IX and X, Lunar Logistics System Mobility on the Lunar Surface, and Payloads, Published by Research Projects Division, MSFC G. von Tiesenhausen, J. R. Olivier, D. C. Cramblit, W. M. McCombs, and R. L. Evans	March 1963	MTP-M-63-1
Launch Deflector Design Criteria and Their Application to the SATURN C-1 Deflector, R. L. Evans and O. L. Sparks	March 1963	NASA TN D-1275
Proposal for Determining the Mass of Liquid Propellants Within a Space Vehicle Propellant Tank Subjected to Zero Gravity Environment, R. L. Evans and J. R. Olivier	March 1963	NASA TN D-1571
Space Vehicle Launch Operations Analysis and Predictions Vol I of II, An Operational Analysis of the SATURN SA-3 Vehicle from Static Firing to Launch, R. T. Burns	April 1963	LIN-DF-63-1
Study Control Handbook, O. K. Duren and A. R. Raffaelli	May 1963	SP-4-3-D

C. FY 1960, 1961, 1962 GOVERNMENT PUBLICATIONS.

<u>Title and Author</u>	<u>Date</u>	<u>Report No.</u>
Major Contributor to United States Army Project Horizon, Vol I and II, G. von Tiesenhausen, J. R. Olivier, and W. E. Dempster	June 1959	---

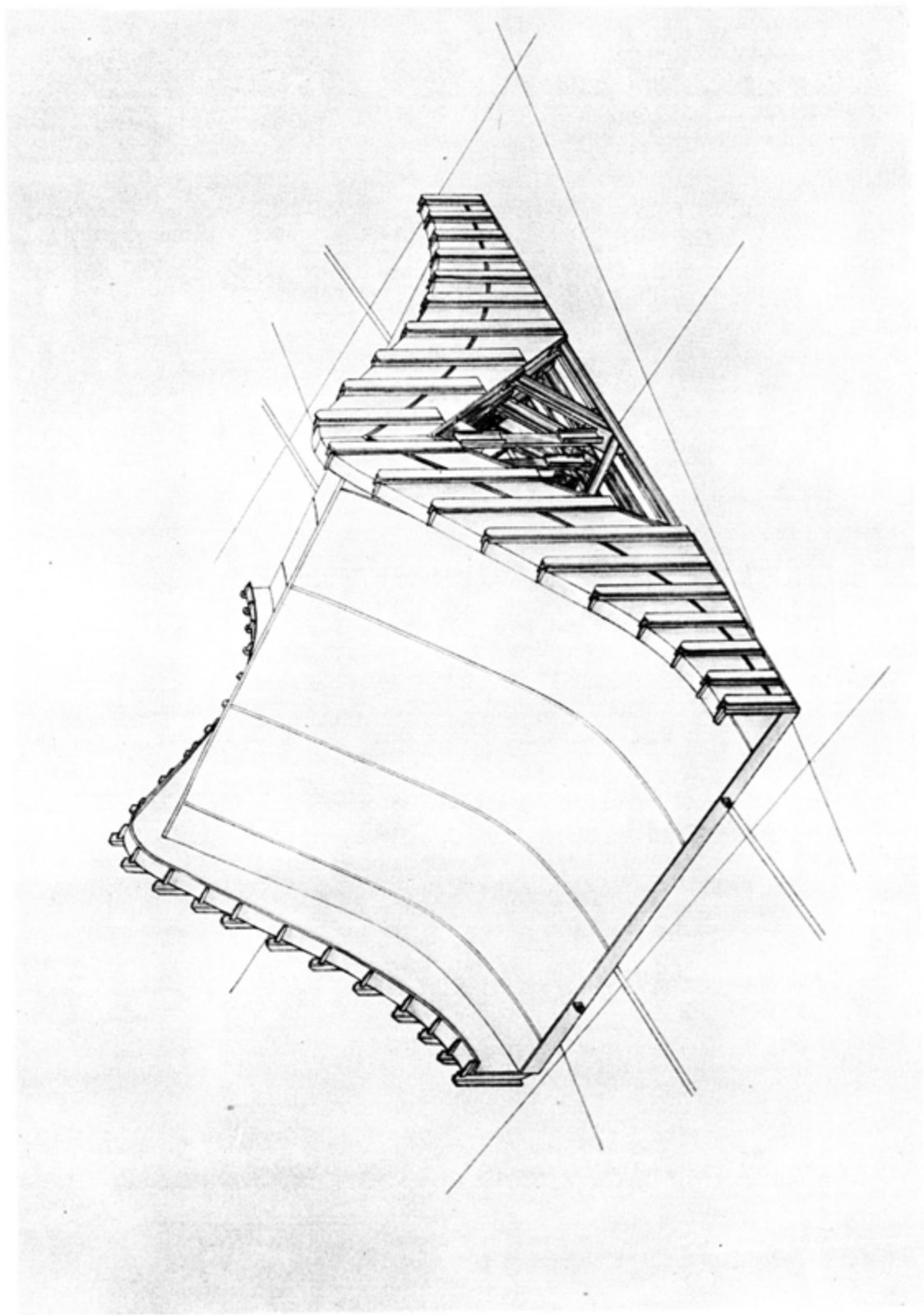

FIGURE 9. LAUNCH COMPLEX 37 DEFLECTOR

<u>Title and Author</u>	<u>Date</u>	<u>Report No.</u>
Design Considerations for a Dry SATURN Deflector, G. von Tiesenhausen	June 1959	DLM-TN-22-59
Development Proposal for a 24-Hour Communications Satellite System Ground Support Equipment, O. L. Sparks	September 1959	DLS-TN-13-59
Lunar Soft Landing Study, O. L. Sparks	December 1959	DLS-TN-26-30
Proposed Test Facility for Ground Test of Space Support Equipment, O. L. Sparks	March 1960	DLS-TN-19-60
Orbital Refueling - A Feasibility Study and Design Concept, Phase I, J. R. Olivier	March 1960	DLM-TN-21-60
Orbital Refueling - A Feasibility Study and Design Concept, Phase II, J. R. Olivier	April 1960	DLM-TN-35-60
A Lunar Subsurface Sampling Device, O. L. Sparks	May 1960	DLM-TN-36-60
Modifications Required on VLF-34 for SATURN C-2 Vehicles (CONFI) O. K. Duren	September 1960	IN-LOD-DL-2-60
SATURN Dyna-Soar Facility and GSE O. K. Duren	December 1960	---
Communications Satellite Program, O. K. Duren	January 1961	Unnumbered
Preliminary SATURN Dyna-Soar Proposal, and Saturn Dyna-Soar Proposal O. K. Duren	February 1961 February 1961	Unnumbered ---
Orbital Storage of Liquid Hydrogen, J. R. Olivier and W. E. Dempster	February 1961	MTP-M-LOD-DL-6-61
Offshore Launch Facility Study O. L. Sparks	April 1961	IN-LOD-DL-6-61
Ground Support Equipment Handbook O. K. Duren	April 1961	---
Interim Report on Future Launch Facilities Study, O. K. Duren	May 1961	MIN-LOD-DL-1-61

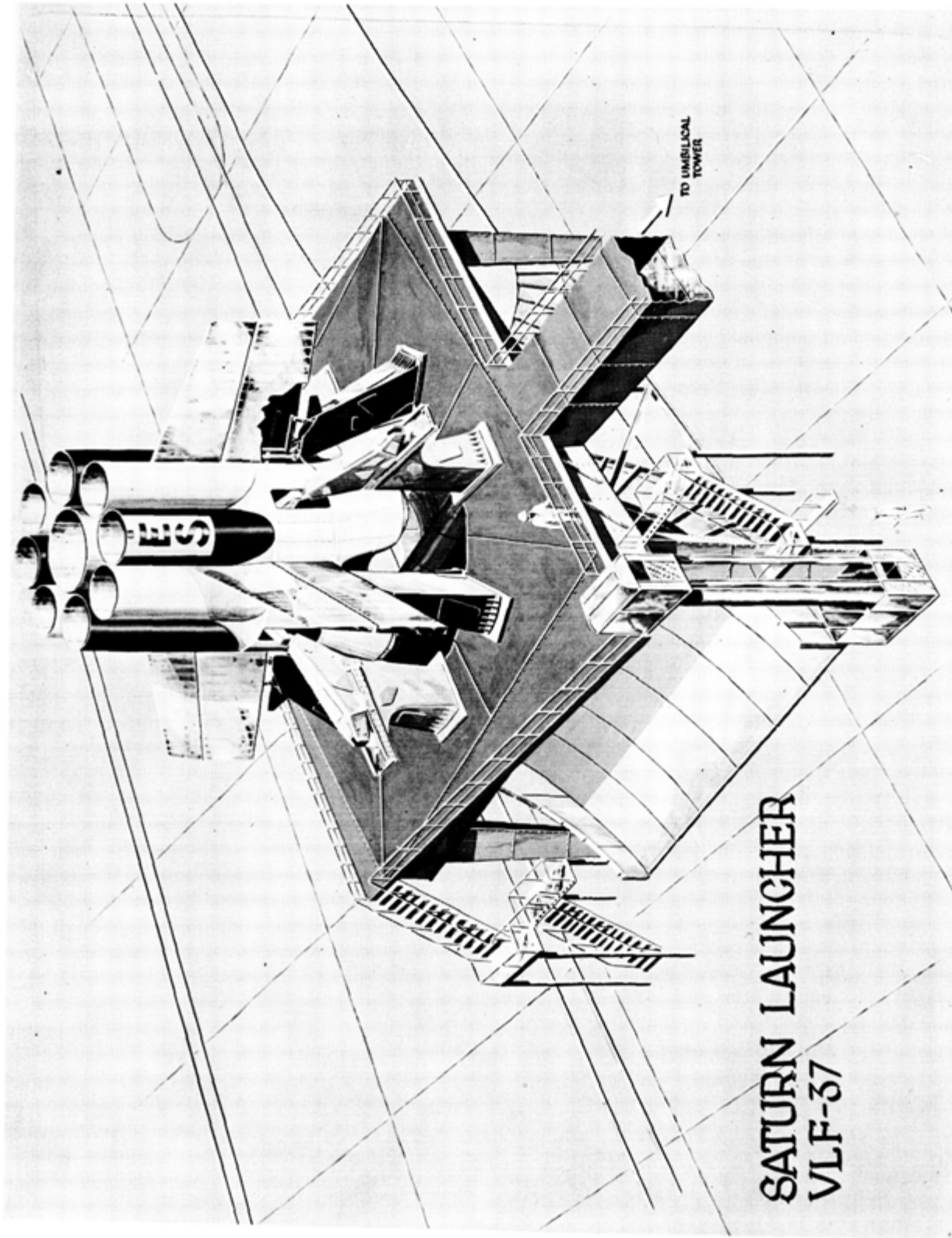

FIGURE 10. SATURN LAUNCHER, VLF-37 (ARTIST'S CONCEPT)

<u>Title and Author</u>	<u>Date</u>	<u>Report No.</u>
Rapid Modes of Transportation for the SATURN System, O. K. Duren	June 1961	---
Preliminary Concepts of Launch Facilities for Manned Lunar Landing Program, O. L. Sparks	August 1961	MIN-LOD-DL-3-61
Orbital Storage of Liquid Hydrogen, J. R. Olivier and W. E. Dempster	August 1961	NASA TN D-559
Flame Deflector Configurations Required for the Attenuation of Exhaust Jets from C-3, C-4, C-4N, and NOVA Space Vehicle Boosters, R. L. Evans	September 1961	MIN-LOD-DL-5-61
Radiation Hazards Associated with the Testing and Launch of a Nuclear Space Vehicle, D. C. Cramblit	November 1961	MTP-LOD-D-61-1
Lunar Storage of Liquid Propellants W. E. Dempster, R. L. Evans, and J. R. Olivier	January 1962	MIN-LOD-DL-1-62
Ground Facility Requirements for Subcooling Liquid Hydrogen, W. E. Dempster and J. R. Olivier	February 1962	MIN-LOD-DL-7-61
Launch Deflector Criteria and their Application to the SATURN C-1 Deflector, R. L. Evans and O. L. Sparks	April 1962	MIN-LOD-DL-5-62
Proposal for Determining the Mass of Liquid Propellant Within a Space Vehicle Propellant Tank Subjected to Zero Gravity Environment, R. L. Evans and J. R. Olivier	April 1962	MIN-LOD-DL-6-62
A Consideration of Lunar Surface Ballistics and the Hazards Associated with Spacecraft Landing or Return Operations, D. C. Cramblit	April 1962	MIN-LOD-DL-8-62
The Launch Probability of Space Vehicles Within a Given Launch Window (SECRET) George von Tiesenhausen and R. L. Evans	May 1962	---

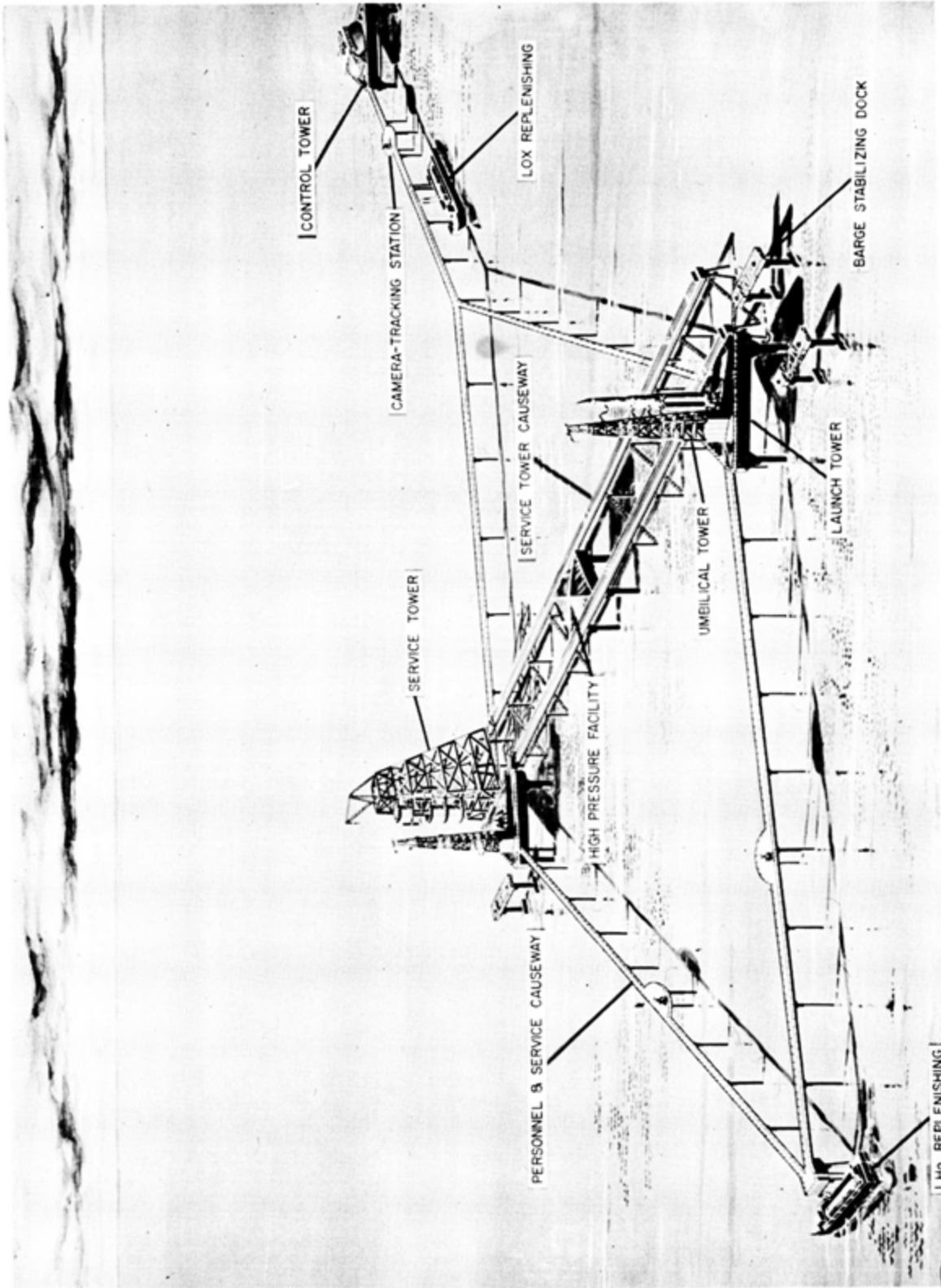

FIGURE 11. SATURN OFFSHORE LAUNCH FACILITY (ARTIST'S CONCEPT)



<u>Title and Author</u>	<u>Date</u>	<u>Report No.</u>
Orbital Launch Facility, J. R. Olivier	June 1962	---
Planning Data for C-5 and NOVA Launch Facilities (SECRET), R. L. Evans	June 1962	---

#### D. MISCELLANEOUS PUBLICATIONS AND PRESENTATIONS.

##### TRADE MAGAZINE PUBLICATIONS

<u>Article</u>	<u>Date</u>	<u>Publication</u>
Launch Facilities and Ground Support Equipment for Launch Complex 34, G. von Tiesenhausen	December 1960	Astronautics
Engineering Problems of Orbital Operations G. von Tiesenhausen	April 1962	Astronautics
Toward the Orbital Launch Facility, G. von Tiesenhausen	March 1963	Astronautics
Gas Laws Help Find Propellant Mass at Zero G, R. L. Evans and J. R. Olivier	June 1963	Space/Aeronautics

CONTRIBUTIONS TO "HANDBOOK OF ASTRONAUTICAL ENGINEERING,"  
McGraw-Hill Book Company 1961, G. von Tiesenhausen

##### LAUNCHING AND HANDLING SPECIAL EQUIPMENT

1. Space Vehicle Launchers
2. Space Vehicle Deflectors
3. Space Vehicle Erection Equipment
4. Umbilical Tower and Service Arms

##### SUPPORT EQUIPMENT FOR EXTRATERRESTRIAL OPERATIONS

1. Orbital Refueling
2. Free-Space Assembly
3. Surface Vehicles for Moon and Planetary Operations

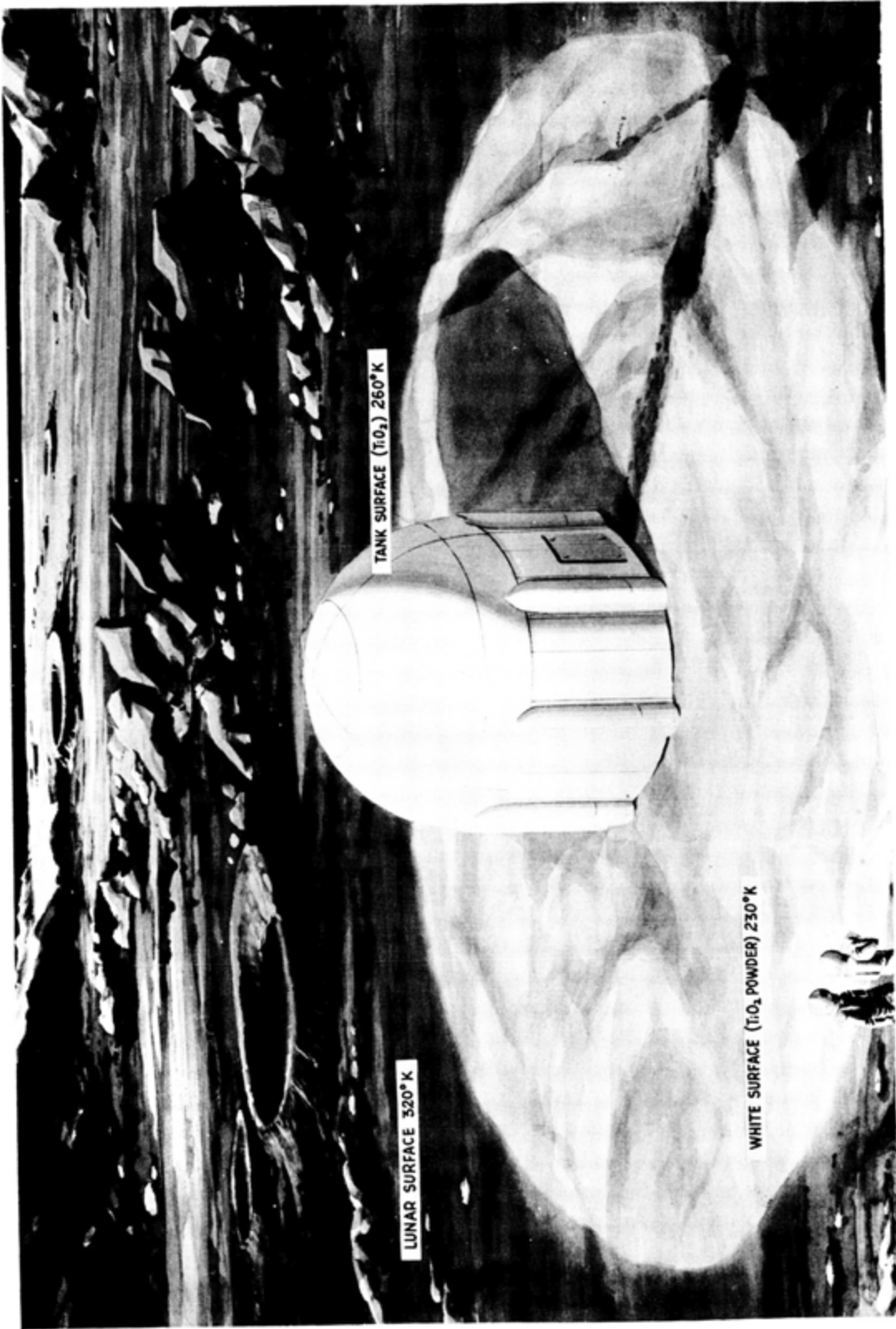

FIGURE 12. LUNAR PROPELLANT DEPOT (ARTIST'S CONCEPT)

## AMERICAN ROCKET SOCIETY PRESENTATIONS

Ground Equipment to Support the SATURN Vehicle G. von Tiesenhausen	December 1960
Orbital Launch Facility G. von Tiesenhausen	January 1963

## INSTITUTE OF THE AEROSPACE SCIENCES PRESENTATION

Orbital Launch Facility G. von Tiesenhausen	January 1963
--	--------------

## PRESENTATION FOR RESERVE OFFICER SEMINARY

Facilities and Support Equipment for the Space Program G. von Tiesenhausen	October 1961
---	--------------

### E. SELECTION OF AVAILABLE MAJOR CONTRACTED STUDY REPORTS.

1. Orbital Docking, Lockheed, February 1961.
2. Facilities Study for Large Space Vehicles With Solid Rocket Boosters, Actron, March 1961.
3. NASA Study of Six- to Twelve-Million-Pound-Thrust Launch Vehicles, North American, August 1961.
4. Two- to Three-Million-Pound-Thrust Launch Vehicle Systems, General Dynamics, August 1961; North American, September, 1961; Martin, September, 1961.
5. Large Launch Vehicle Subsystems, Lockheed, October, 1961; NAA, October, 1961.
6. A Study of Large Launch Vehicle System for a Manned Lunar Landing Program, General Dynamics/Astronautics, October, 1961.
7. Acoustical Considerations in Launching and Static Testing of Large Space Vehicle Boosters, by Bolt, Beranek, and Newman, December, 1961.
8. NERVA Engine Development Program and Associated Tasks, July, 1961 through January, 1962, Aero-Jet General Corporation.
9. Study of Large Launch Vehicles Utilizing Solid Propellants, Boeing, February, 1962.
10. Analysis of Medium Class Vehicles, Space Technology Laboratory, February, 1962.

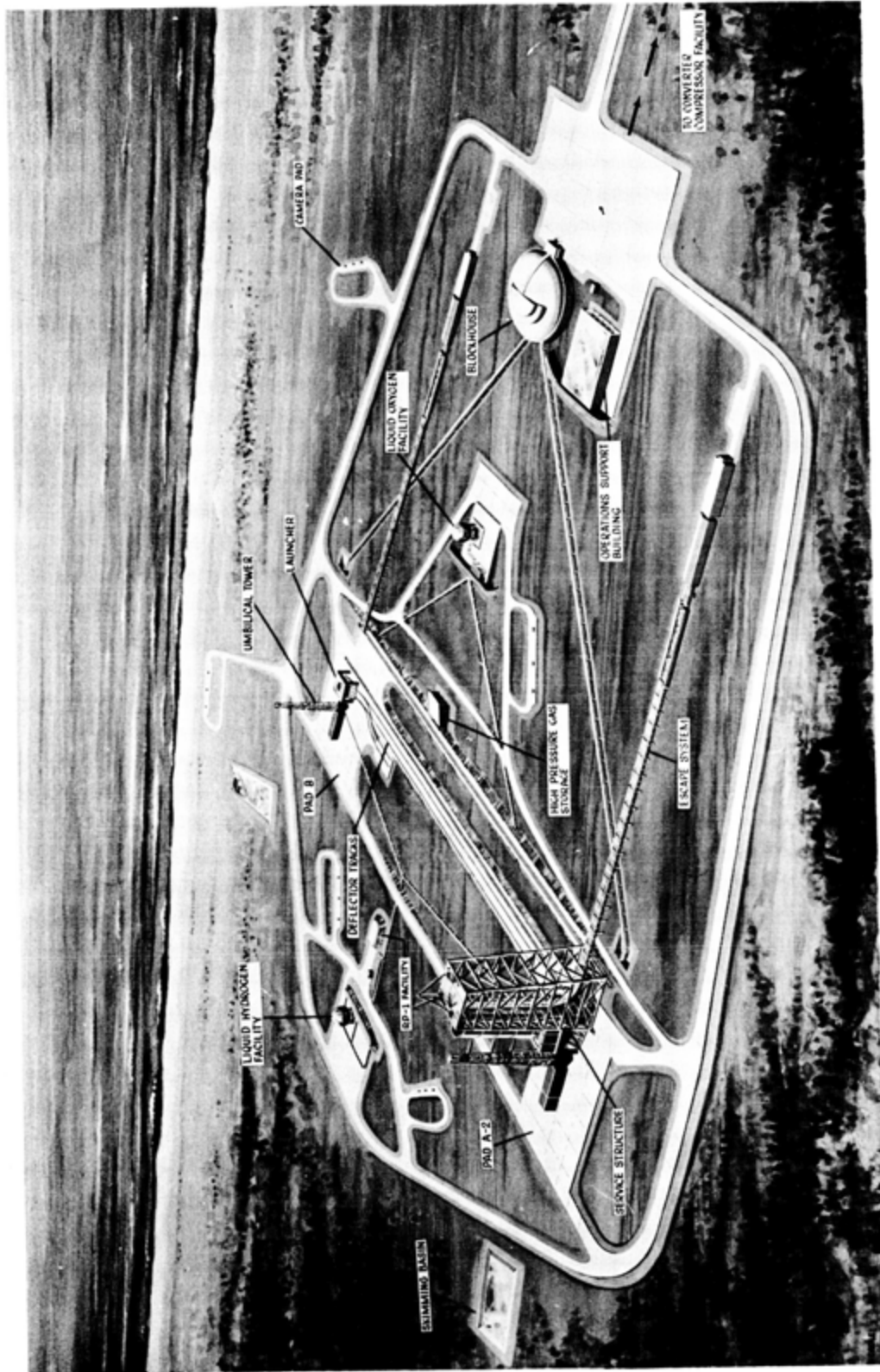

FIGURE 13. SATURN LAUNCH FACILITY (ARTIST'S CONCEPT)

11. Equatorial Launch Sites, Chrysler Corporation, July, 1962.
12. Ground Support Equipment Design for Operation in Severe Acoustic and Vibration Environments, Hayes International, August, 1962.
13. Saturn Launch Study (On Site Assembly) Martin, September, 1962.
14. Study of Large Launch Vehicles Using Solid First Stages, Boeing, December, 1962.
15. Reusable Ground Launch Vehicle Study 50 - 100-Ton Orbital Payload, Boeing, December, 1962.
16. Earth Lunar Transportation System, Study of an Advanced Lunar Transportation System, Martin, December, 1962.
17. Advanced Lunar Transportation System, Nuclear Ferry Vehicle Study, General Dynamics/Astronautics, January, 1963.
18. Advanced Lunar Transportation Study, Lockheed, January, 1963.
19. Comparative Study of Advanced Lunar Transportation Systems, Chance-Vought, January, 1963.
20. Conceptual Design Study of 50 - 100-Ton Reusable Orbital Carrier, NAA, February, 1963.
21. Reusable 10-Ton Orbital Carrier Vehicle Final Report, Phase I, Lockheed (Calif.), February, 1963.
22. Conceptual Design Study of 10-Ton Reusable Orbital Carrier, NAA, February, 1963.
23. NOVA Launch Facilities Study, Phase 1 Report, Martin/Denver, March, 1963.
24. Post NOVA Launch Vehicle Study, Douglas, April, 1963.
25. Solid-Boosted NOVA Vehicle System Study, Boeing, April, 1963.

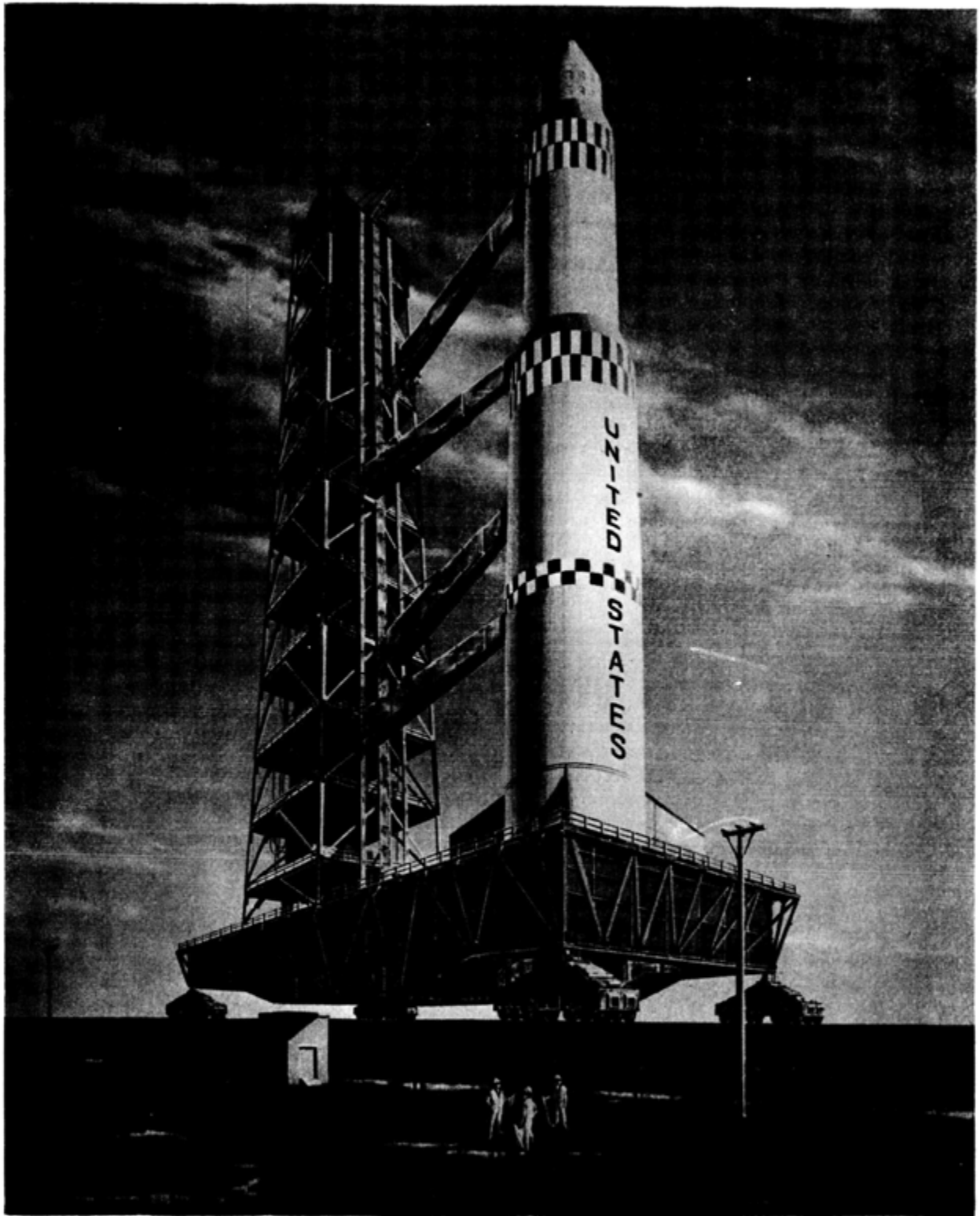

FIGURE 14. SATURN MOBILE LAUNCHER/TRANSPORTER-RAIL CONCEPT

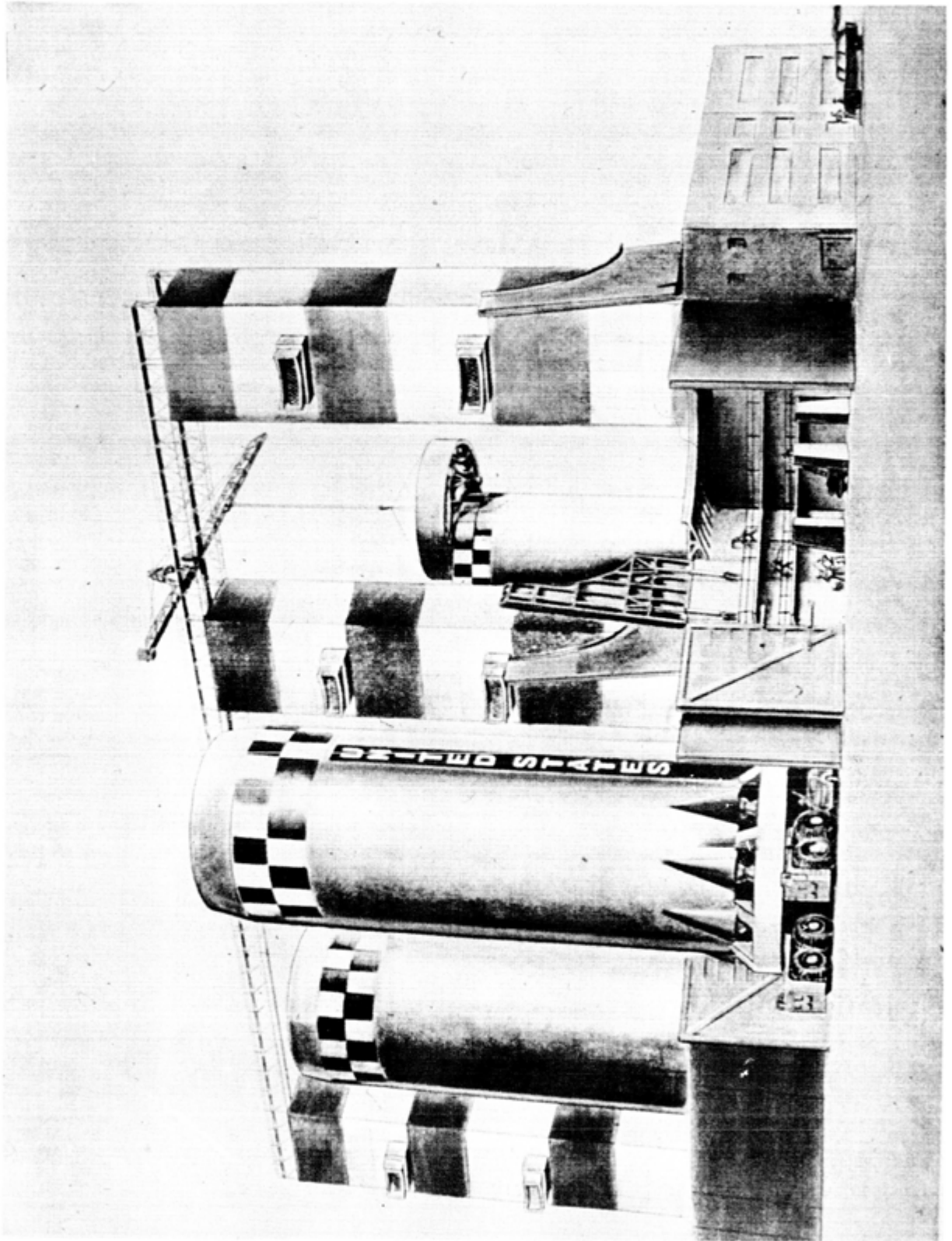

FIGURE 15. NOVA STAGE CHECKOUT AREA (ARTIST'S CONCEPT)

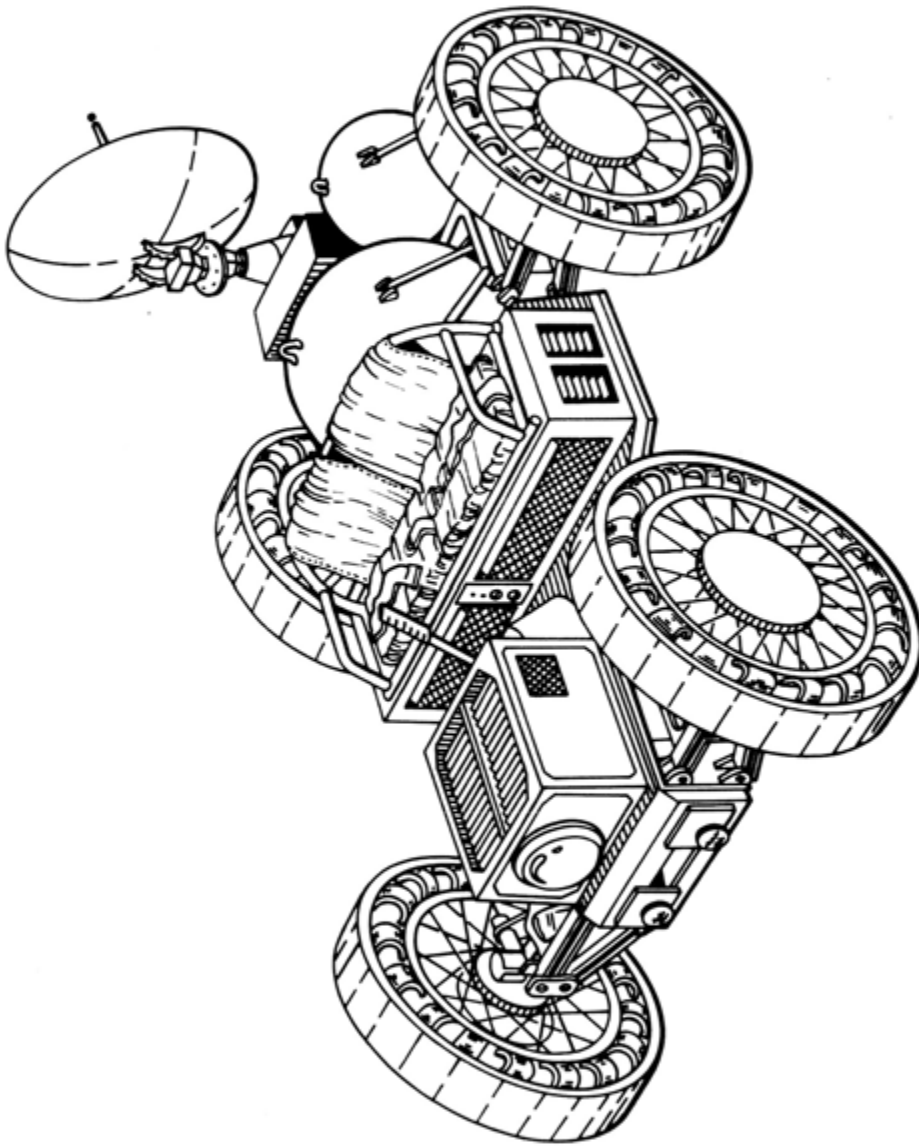

FIGURE 16. 2,500-POUND LUNAR ROVING VEHICLE (ARTIST'S CONCEPT)



SECTION VIII  
FISCAL YEAR 1963 IN-HOUSE STUDY PROGRAMS

**A. LUNAR LOGISTICS SYSTEM.**

Considerable effort has been expended supporting phases of the Lunar Logistics System which is under the aegis of the Research Projects Division of MSFC.

The purpose of this investigation was to review mobility analysis and techniques, and to establish preliminary criteria for the development of a lunar roving vehicle. Primary emphasis was placed on a parametric mobility analysis from which soil characteristics, modes of locomotion, vehicle peak torque, power requirements, and energy requirements were established. The data provided are of a parametric nature, and may be used to evaluate the performance of a vehicle on a range of various soils and terrains. Considerations were also given to basic steering arrangement systems, suspension systems, drive systems, and powerplant concepts.

The study shows that the optimum means of locomotion is a four-wheel-drive vehicle which employs large diameter, narrow tread, semirigid, noninflated wheels, and is front-wheel steerable. The preliminary criteria established have been utilized as the basis for establishing a follow-on conceptual design of a lunar roving vehicle. For further details, see "Mobility on the Lunar Surface," MTP-M-63-1.

**B. INVESTIGATION OF CHECKOUT PROCEDURES IN QUALITY ASSURANCE DIVISION AND LAUNCH OPERATIONS CENTER.**

Because of the increased complexity of space vehicles, the problems associated with ground launch operational scheduling, timing, checkout, and sequencing have become more stringent. The Future Studies Branch directed considerable study effort towards the development of techniques enabling the prediction of prelaunch checkout and launch contingencies to increase the probability of success in future space missions, and to assist in studies being made concerning launch vehicle preparation and checkout requirements, component reliability, and checkout difficulties. For further information, see "An Operational Analysis of the SA-3 Vehicle," LIN-DF-63-1.

**C. LAUNCH PROBABILITIES.**

Future space missions impose many stringent requirements on the space vehicle, for example, maintaining launch timetable (launch window) associated with the rendezvous of space vehicles in earth orbit. Presently, the launching of such vehicles has come under careful scrutiny inasmuch as a hold during the final countdown of a vehicle may result in the miss of a launch window and scrub of a mission. In order to insure that the launch timetable is kept, investigation was conducted to determine the built-in hold times required to meet a launch window for various probabilities of success. This investigation, which utilized the past histories of some 126 vehicles for extrapolation to the larger

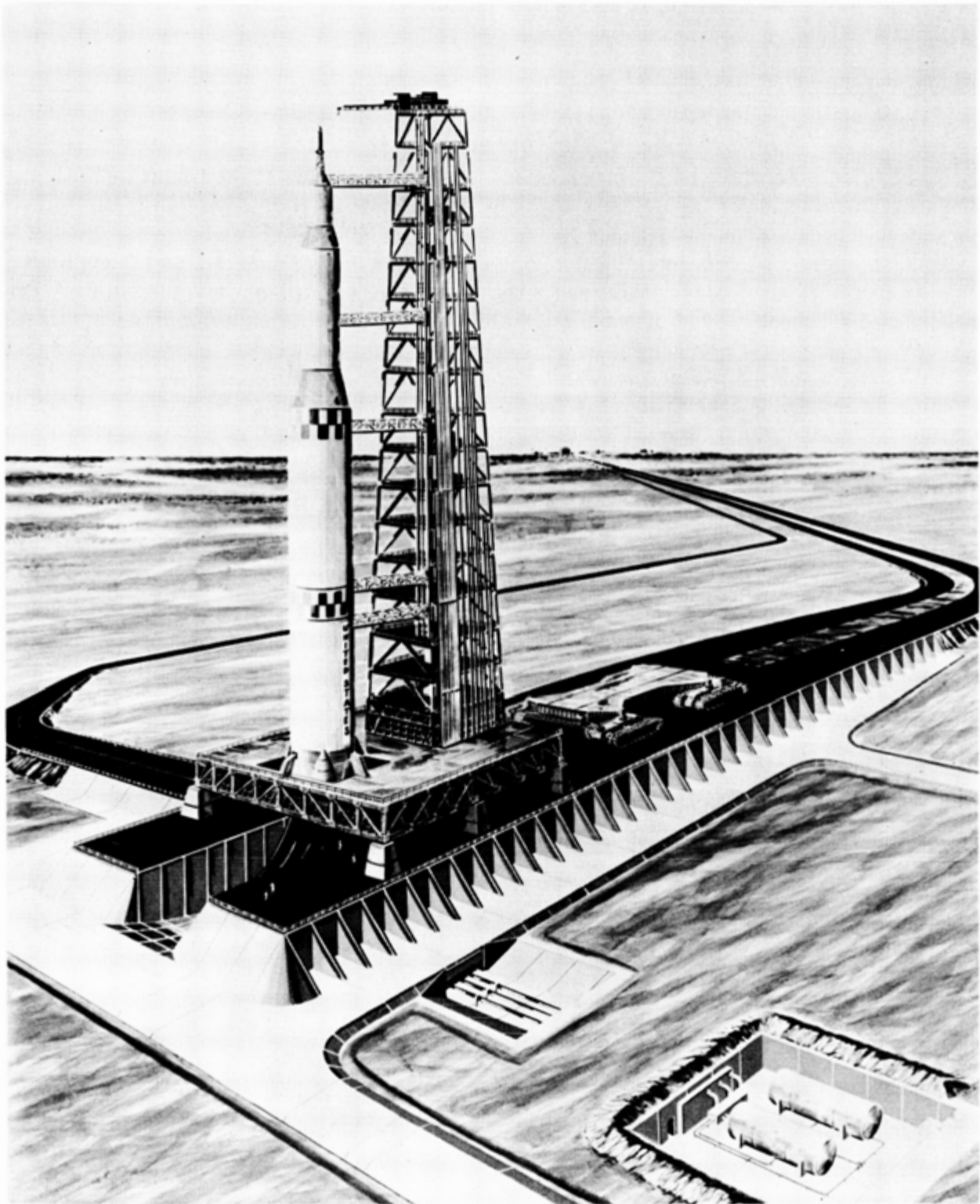

FIGURE 17. SATURN CRAWLER (ARTIST'S CONCEPT)

space vehicles, had shortcomings in establishing relationships between vehicles. This investigation was continued utilizing a Monte Carlo statistical analysis approach in an attempt to establish a relationship between various launch vehicles.

Additional study effort, utilizing weighted hold times and statistically extrapolated launches employing the 7090 computer, yielded the most satisfactory results. The final results of this effort have been organized and plotted for Redstone-Jupiter (with excellent statistical reproduction of real data) and of more current interest - Saturn IB and Saturn V space vehicles. The results are presently being evaluated by appropriate divisions within LOC.

#### D. RIFT PROGRAM.

Continuous effort has been directed toward coordination of the Reactor-In-Flight Test (RIFT) Program for LOC, Huntsville. This includes participation in safety and hazards analysis working groups, engine review committees, and other working groups responsible for monitoring and directing contractor study and design efforts. This function involves daily support and coordination with the Nuclear Vehicle Project Office of MSFC regarding RIFT Program operations pertaining to launch facilities and ground support equipment. This type of in-house effort will ultimately result in the development and specification of detailed design criteria for nuclear facilities and ground support equipment at the Atlantic Missile Range (AMR).

#### E. LUNAR TANKER - SATURN V.

Effort was initiated toward development of preliminary criteria and conceptual design of a cryogenic storage tanker to support the Lunar Orbital Rendezvous (LOR) Program. The program, in addition to manned payloads, will involve a number of cargo payloads in support of the overall mission. Cryogenics will be one of the major cargo payloads, and may be used for both lunar orbital operations or for resupply of lunar surface storage facilities. This work was performed to support MSFC efforts in the development of such a tanker. Solutions of problems associated with heat transfer, propellant transfer techniques, insulations, storage pressures, and meteoroid protection have been given major consideration.

#### F. HIGH PRESSURE GAS STORAGE - EARTH.

A detailed optimization study was initiated to investigate the interrelationships between the various parameters affecting gaseous storage tank design. Wall thickness, tank configuration, tank materials, heat transfer considerations, optimized storage pressure versus volume considerations, and gaseous composition are being thoroughly investigated for earth environment.

#### G. HIGH PRESSURE GAS STORAGE - SPACE.

Earth orbital space stations and space vehicles require gases to activate various mechanical devices, to control environment, to provide life support, etc. Seemingly,



FIGURE 18. ORBITING SCIENTIFIC LABORATORY (ARTIST'S CONCEPT)

the logical method of storing these gases would be at high pressure and relatively low volume. However, there are a number of parameters to be considered in arriving at an optimized solution. This study was initiated to investigate the parameters associated with the storage of high pressure gas in an extraterrestrial environment, and to optimize these parameters with respect to weight, stress, heat transfer, and economics.

#### H. ORBITAL LAUNCH FACILITIES.

In anticipation of future requirements, considerable effort has been directed toward the development of a proposed orbital launch facility capable of performing repair, checkout, and launch operations for space vehicles. These efforts have resulted in the proposal of an evolutionary orbiting facility composed of two major portions: a scientific laboratory and an orbital launch facility; each of which is a SATURN V payload. Investigation of checkout and repair concepts, major engineering problems (such as meteoroid protection), systems weight distribution, crew psychological effects, and the compatibility of such a payload with currently planned vehicles and launch facilities, are some of the major problem areas still under consideration.

#### I. COMPLEX 39 LAUNCH FACILITIES.

Continuous effort has been directed toward development, design, and evaluation of Launch Complex 39 facilities, ground support equipment, and operational procedures. Current support effort is being directed toward assisting in the development, design, and layout of a proposed Complex 39 launch pad area with associated support facilities.

#### J. SPACE MAINTENANCE AND REPAIR COMMITTEE.

This committee was established to monitor, control, and direct both in-house and contractual studies related to orbital operations techniques, evaluation of man's capabilities in space for performance of maintenance and repair tasks, and development of tooling and vehicle configurations compatible with man's predicted capabilities in space. Current studies are establishing concepts for maintenance techniques, space station and orbital launch facility assembly techniques, repair techniques for systems components, tool design criteria, remote manipulator requirements and criteria, and future hardware development requirements.

#### K. NERVA ENGINE REVIEW COMMITTEE.

This committee, comprised of representatives from MSFC and LOC, was established to review, monitor, and evaluate all aspects of the NERVA engine development program, with special emphasis being placed on design problem areas and engine/stage interface development. This committee is keeping abreast of all developments in the engine program, and is serving as a central planning and coordinating office for MSFC and LOC on all aspects of the engine/stage integration program of combined interest to MSFC, LOC, SNPO, Aero-Jet General, and Westinghouse.

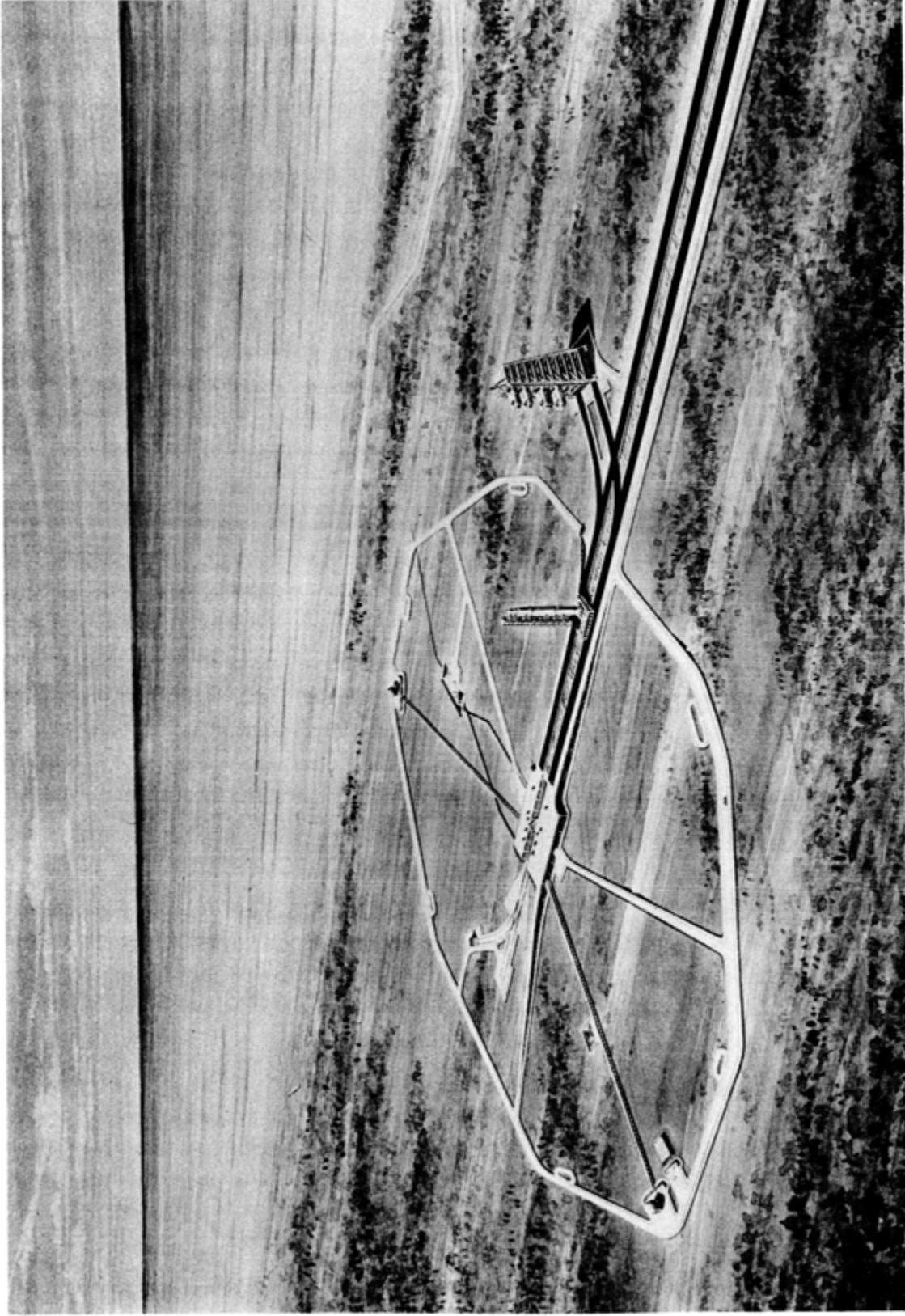

FIGURE 19. LAUNCH COMPLEX 39, PAD AREA CONCEPT



#### L. NUCLEAR SAFETY AND HAZARDS WORKING GROUP.

By a joint agreement between the Atomic Energy Commission (AEC) and NASA, the AEC will retain review responsibility on the operational safety of nuclear flight systems. To help insure that the RIFT flight test systems will meet all the AEC imposed requirements, the group was established and has been acting as a focal point within MSFC and LOC to identify potential nuclear hazards, to propose methods of hazard and safety analysis, and to propose possible design or operational counter measures.

#### M. LAUNCH FACILITY REQUIREMENTS FOR NUCLEAR STAGES.

To assist in planning and site layout of Launch Complex 39 for the provision of nuclear upper stages, and the development of basic facility criteria for the nuclear assembly building as required for reactor/engine assembly and checkout and stage/engine integration and checkout, preliminary study efforts are required in the area of failure effects analysis for all conceivable launch operational modes, nuclear stage/engine assembly, handling and checkout requirements, and safety requirements. Remedial procedures are being defined for postulated accidents. Some study efforts are being directed along these lines by the RIFT stage contractor as specified in the current NASA contract. The exact scope of work to be covered by this study contract will be governed by the level of effort and caliber of data generated by these initial-stage contractor studies, and will be thoroughly defined later. The ultimate goal of this study is to provide detailed design and safety criteria for the development and planning of nuclear launch facilities, ground support equipment, and associated operational procedures.

#### N. LIGHTNING PROTECTION SYSTEMS FOR FUTURE SPACE VEHICLES, LAUNCH FACILITIES AND GROUND SUPPORT EQUIPMENT.

This study assisted in evaluating the detailed design criteria for a system capable of protecting future space vehicles and associated umbilical towers, service structures, launcher/transporters, and supporting electronics systems from the destructive effects of lightning discharges.

The SATURN V launch vehicle, umbilical tower, and crawler launcher/transporter combination for Complex 39 will be the tallest structure in the state of Florida. It will be highly susceptible to the receipt of lightning discharges. To eliminate the potential hazards associated with a high-current flow through delicate electronic systems and pyrotechnics systems, the entire vehicle, umbilical tower, transporter/launcher, and service structures must be grounded at all times while on the launch pad and during transit from the Vertical Assembly Building to the pad. Transit time from the pad back to the VAB will encompass some two to three hours minimum. This time requirement eliminates consideration of returning to the VAB for protection in the event of an impending storm because of the frequency and sometimes spontaneous nature of storms in the immediate area.

This would also conflict with one of the basic principles upon which the SATURN V mobile concept was founded; namely, the vehicle would be capable of "free-standing"

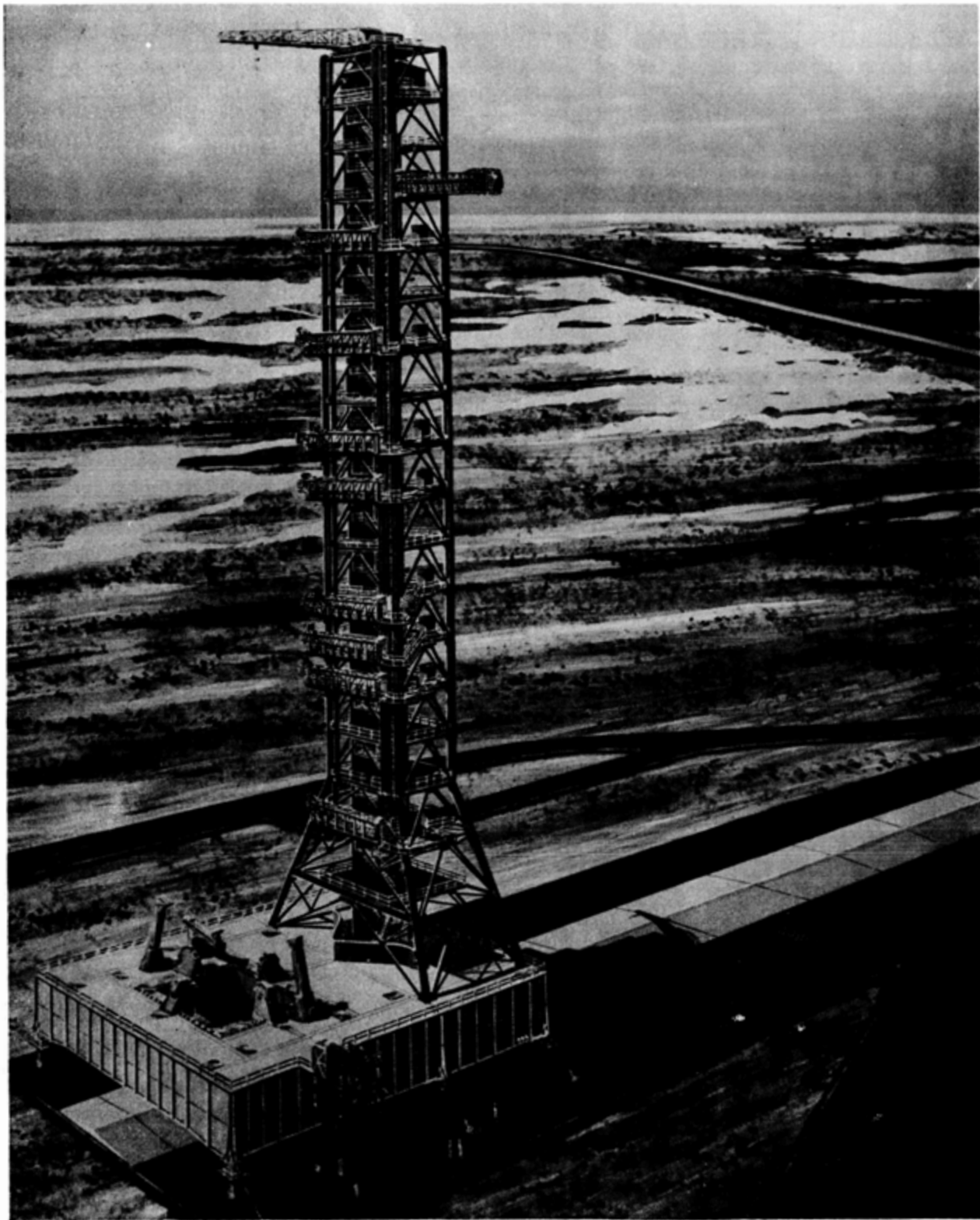

FIGURE 20. LAUNCHER/UMBILICAL TOWER AT REFURBISHMENT AREA  
(ARTIST'S CONCEPT)



without external support in three-sigma wind conditions. Thus, the vehicle will be developed with the capability for remaining on the pad during a majority of storms that occur in the Cape and MILA area. Detailed preliminary studies have been performed to investigate the physical nature and basic characteristics of atmospheric lightning discharges, and conceptual approaches to an adequate grounding system capable of protecting the vehicle and ground support equipment from stray voltages and/or high current discharges at all times. For further information, see "Introduction to Lightning," LTIR-2-DF-62-6.

#### O. OVERWATER JET IMPINGEMENT.

Present and near future launch complexes can be accommodated at MILA for vehicles up to and including the Saturn V vehicle. However, the unavailability and prohibitive costs of real estate required to accommodate launch complexes beyond the Saturn V vehicle have made it advisable that investigations be conducted now to determine other methods for launching space vehicles.

Overwater launching of space vehicles is being considered due to the non-availability of launch sites. To render a decision on the feasibility of this approach, many technical decisions must be made. This study is an effort to determine the more important parameters associated with an overwater type, launch complex to aid in rendering the technical decisions necessary for successful future programs.

#### P. FACILITY REQUIREMENTS DUE TO EROSION EFFECTS OF SOLID PROPELLANT ROCKET EXHAUST.

Launching of large solid propellant boosters introduces new launch facility requirements due to the highly erosive effects of the solid particle content of the engine exhaust. This study is being conducted in conjunction with a suitable test program to optimize flame deflector design concepts for attenuating the rocket exhaust gases, and to develop an economical method for protection of those components of the launch facilities exposed to the exhaust stream as the vehicle ascends.

#### Q. PREDICTION OF OBJECT MOTION IN A VACUUM WHEN SUBJECTED TO ROCKET ENGINE EXHAUST GASES.

With the advent of lunar landings planned for the near future, it is essential that considerable thought be given to the behavior of jet exhaust in a vacuum under low gravity conditions, especially in relation to the most probable lunar surface conditions. Of primary concern is the motion of lunar surface particles resulting from the impingement of exhaust gases from the lunar landing or takeoff of a space vehicle and the resulting hazards to the vehicle itself, and to both local and distant manned lunar bases and facilities. The combined parameters of low gravity, high vacuum, and high energy exhaust gases result in the displacement of large masses over considerable distances, so that the problem is not merely a localized one. In-house studies have covered the basic ballistics on the lunar surface, and also the partial orbits and escape trajectories that may be attained by such particles. A comparison of the lunar surface escape velocity with the considerably larger exhaust gas velocities alone serves to indicate that the problem is

very real, especially when considering that many of the early lunar base facilities may be constructed of inflatable, relatively easily puncturable materials.

In-house studies have indicated the velocity ranges and ballistics to be encountered on blast-accelerated lunar particles. The masses of particles that will most probably be accelerated to these velocities must be determined.

It is hoped that through a detailed analytical study, coupled with supporting model testing, some reasonable empirical relationships will be established that will permit the writing of parametric equations defining particle motion with time up to the time when maximum velocity is attained. The Lewis Research Center has performed some preliminary model test work with highly, under-expanded jet nozzles in a vacuum that is of some qualitative value. However, much more definitive testing appears in order for the solution of this proposed study. The equations developed should not be based on any specific thrust level or nozzle configuration, but rather should include data relating the surface pressure distribution to parameters of nozzle area ratio, nozzle chamber pressure, nozzle contour, and height of the nozzle above the surface. Model testing by the Lewis Research Center in a vacuum has indicated that such relationships can be established. For further details, see "Lunar Surface Ballistics," NASA TN D-1526.

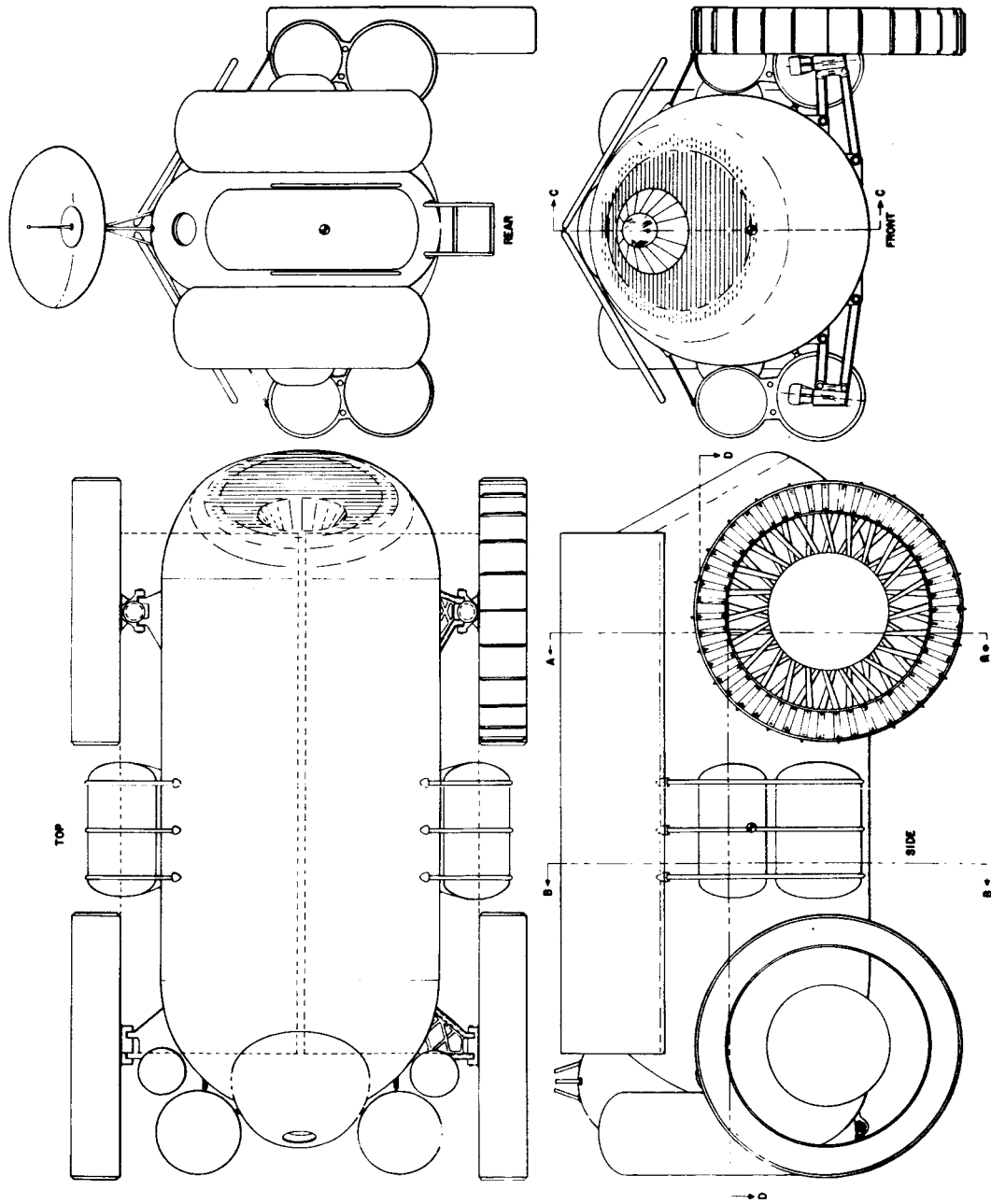

FIGURE 21. EXTERIOR VIEW OF 10,000-POUND LUNAR ROVING VEHICLE (ARTIST'S CONCEPT)

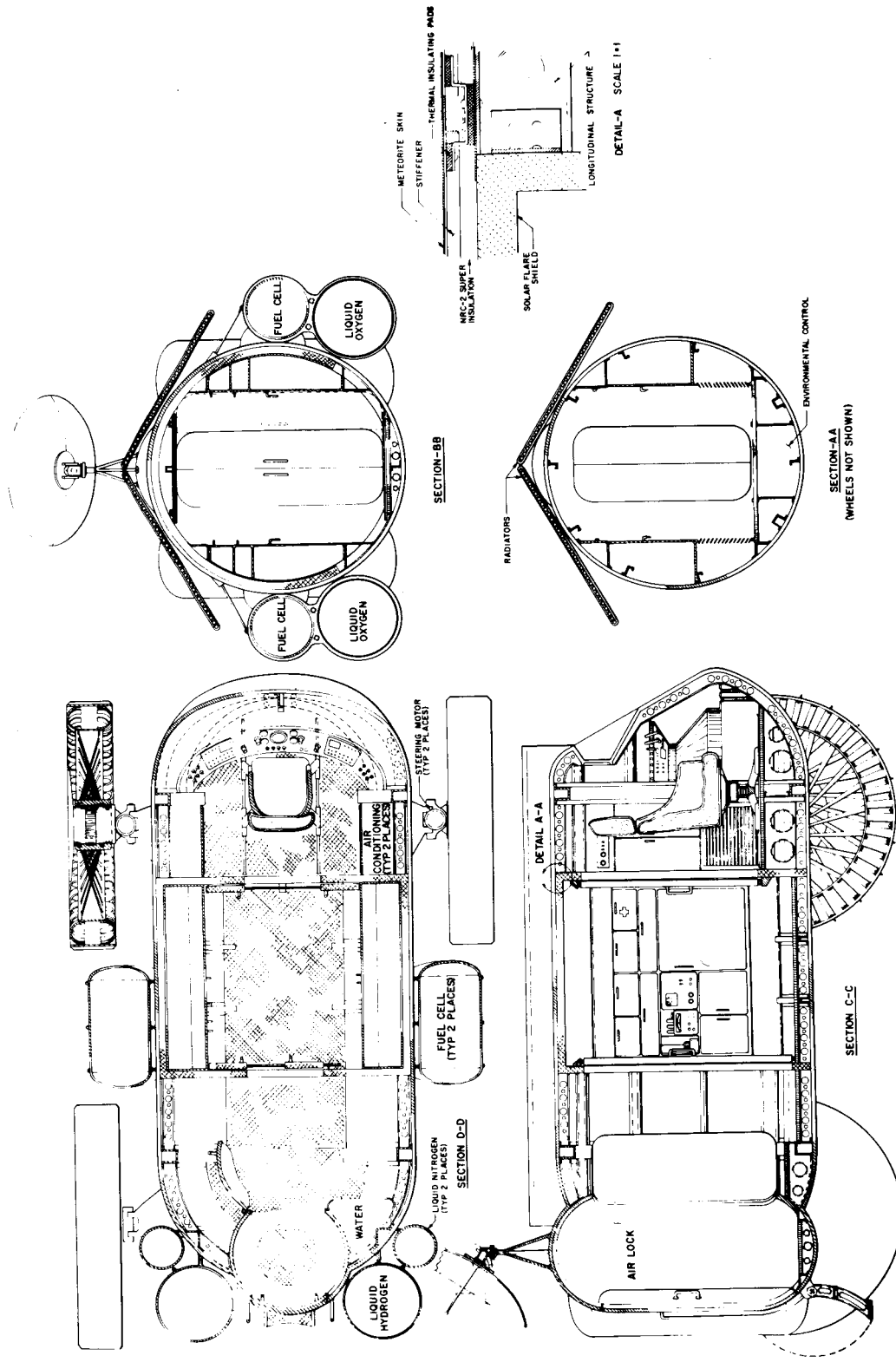

FIGURE 22. INTERIOR VIEW OF 10,000-POUND LUNAR ROVING VEHICLE (ARTIST'S CONCEPT)

## SECTION IX CURRENT IN-HOUSE STUDY PROGRAM

### A. LUNAR LOGISTICS SYSTEM.

The Space Launch Section of the Future Studies Branch is currently working on several aspects of the proposed Lunar Logistics System (LLS) in support of the Special Assignments Office of MSFC.

In the past, this branch has been closely associated with various engineering studies on lunar storage, facilities, and mobility, and due to familiarization with lunar surface conditions and the effects on equipment, has been called on to provide continuing engineering support for mechanical systems development of the future Lunar Roving Vehicle (LRV).

Preliminary work statements, test and development programs, and facility requirement definitions have been generated for the proposed Lunar Roving Vehicle. Five specific areas of investigation are currently receiving attention.

1. Long-Term Cryogenic Storage. The most promising prime powerplant for the LRV appears to be a hydrogen-oxygen fuel cell. A design guideline calls for the capability of unmaintained or unserviced inactive vehicle storage on the lunar surface up to one year. Considerable effort is being made to determine the duration cryogenic hydrogen and oxygen may be stored on the lunar surface either in spherical or cylindrical tank configurations. The investigations will determine optimum tank size, weight, insulation thickness, time stored at constant density, time at constant pressure, and propellant weight loss during the vent period.

2. Lunar Roving Vehicle Radiator Analysis. This is a comprehensive examination of the parameters affecting the size, construction, and configuration of a heat rejecting finned tube radiator for all heat loading systems of the LRV, including the prime mover. The influence of radiator tube diameter, cooling fluid velocities, surface thermal properties, and operating temperature will be investigated to determine optimum design criteria.

3. Four- to Six-Wheel Mobility Analysis. This study will compare the characteristics of a four-wheeled LRV concept with a rigid chassis to a six-wheeled LRV concept with a jointed chassis. The primary characteristics to be compared are power requirements, obstacle negotiation, system complexity, and reliability to determine the overall optimum mechanical system.

4. Lunar Surface Mile Profile. Efforts are being directed towards synthesizing a standard lunar linear mile for analyzing LRV dynamic requirements and power requirements. Various approaches, including a computer program to randomize the distribution of slopes and frequency of obstacle size and occurrences, are being investigated.

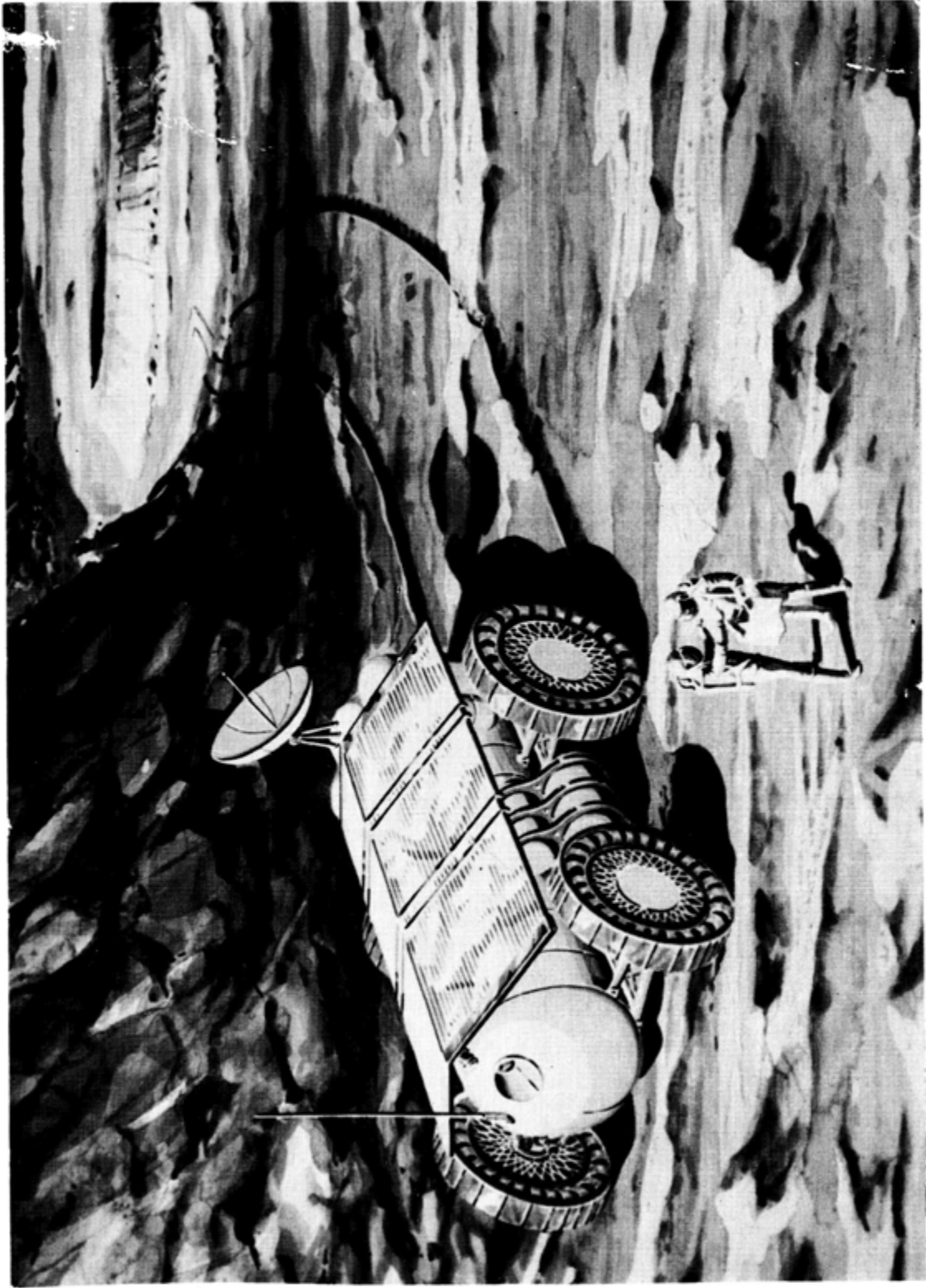

FIGURE 23. ARTIST'S CONCEPT OF A 10,000-POUND LUNAR ROVING VEHICLE

5. Thermal Control. This study encompasses an investigation into temperature control of the LRV electric drive motors under assumed operating conditions - prolonged operation on level surfaces, slope climbing, intermittent heavy power demands, and possible dynamic breaking. Other heat generating LRV systems will also be investigated.

#### B. CONTRACT WORK STATEMENTS.

In-house preliminary studies are being performed in preparation for writing work statements for the FY 1964 planned out-of-house study contracts. The preliminary in-house studies aid in the writing of comprehensive, effective statements of work and provide assistance in developing study ground rules, assumptions, and guidelines. (See Section XI, page 60, Fiscal Year 1964 Contract Study Program).

The titles of the studies currently being pursued in-house are:

- Leak Detection Methods
- Reduction of LH<sub>2</sub> Boiloff Rates
- Helium Use and Reuse
- High-Pressure Flexible Hoses, and Couplings
- Cryogenic Hoses, and Couplings

#### C. ADVANCED ORBITAL LAUNCH OPERATIONS.

The Marshall Space Flight Center is performing, with the assistance of Ling-Temco-Vought, Inc., a study entitled "Advanced Launch Operations." The results of this study, which is heavily supplemented with this branch in-house efforts, will be design criteria for earth and orbital facilities that will be required for the space program in the post-APOLLO period through the 1980 time period.

In order to achieve maximum benefit of this study, the Future Projects Office of MSFC has requested the Future Studies Branch of LOC to actively participate in the study, particularly in the areas of countdown and checkout philosophy. Accordingly, this branch is providing assistance primarily in the following two ways: First, a representative from this branch is a member of the technical panel which provides guidance on tasks associated with countdown and checkout philosophy. Second, this branch is furnishing information on facilities that will be available for use in the time frame under consideration, and information on checkout and countdown procedures that are presently used by operational personnel at the Cape, and pertinent information derived from other studies performed by this branch. As formal contributions are submitted to MSFC, they are inserted into a document entitled "LOC Contributions to MSFC Advanced Orbital Launch Operations Study," so that a systematized running account of all information is maintained.

#### D. EXOTIC PROPELLANT FACILITIES.

Future launch vehicles may require fluorine- and boron-based fuels. So that LOC is prepared to consider this eventuality, a preliminary study is being organized to examine the facilities, support equipment, and hazards associated with fluorine, chlorine trifluoride,

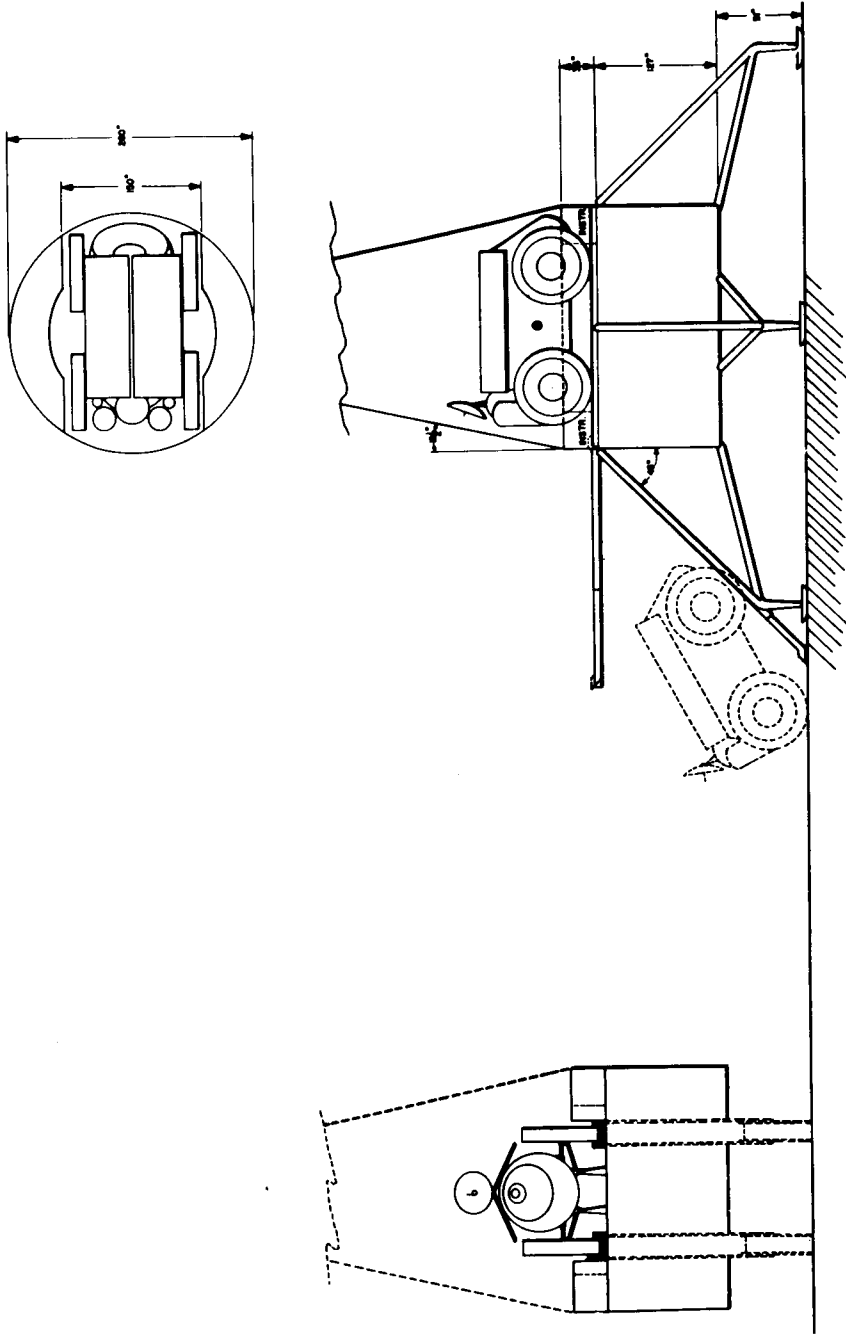

FIGURE 24. LUNAR EXCURSION MODULE WITH THE LUNAR ROVING VEHICLE



diborane, pentaborane, decaborane, and similar propellants. A complete review of possible future fuel and oxidizer combinations that may be used at AMR will be performed. This review may also include study of the effect of metallic additives for various fuels as well as thixotropic propellants on launch facilities, equipment, and procedures.

#### E. SUPPORTING TECHNOLOGY AND ADVANCED STUDIES CONTROL HANDBOOK.

This handbook provides a centralized control information source on Supporting Technology and Advanced Studies for which the Launch Operations Center is responsible. It contains all available study control information for fiscal years 1963, 1964, and 1965, and is designed to be used by all interested functions. The information will be kept current at all times with the distribution of revision sheets. It is also intended to aid study management team members in directing and supervising studies for which they are responsible.

Copies of the control handbook are available to appropriate parties upon request to LO-CP or LO-DF, Launch Operations Center.

#### F. HIGH-PRESSURE GAS STORAGE.

The two-part study on High-Pressure gas storage (earth and space) is being continued into fiscal year 1964.

This is a parametric study to optimize High-Pressure gas facilities with respect to cost and weight in all expected environs.

#### G. LAUNCH FACILITY NUCLEAR SAFETY.

This is a continuing study effort to keep LOC abreast with the advancing technology of nuclear rocket engines. Eventually, nuclear propulsion stages will be an actuality and the Launch Operations Center must be prepared.

#### H. THERMAL DESIGN OF LAUNCH DEFLECTORS.

The lack of explicit information on thermal design of launch deflectors for large space vehicles has given cause for studies to be initiated by this branch to gain further insight into this area.

A computer program has been written to determine the temperature profile within a launch deflector plate as a function of time. The program, which considers the plate to be insulated on one side and exposed to the severe temperature effects of the rocket exhausts on the other, calculates the heat transfer coefficient at a point on the deflector surface. A plot of a series of these points will yield the overall effective average coefficient. A further refinement of the program, which is based on Dusenberre's methods, incorporates the variations of thermal conductivity and diffusivity of the plate material under consideration.

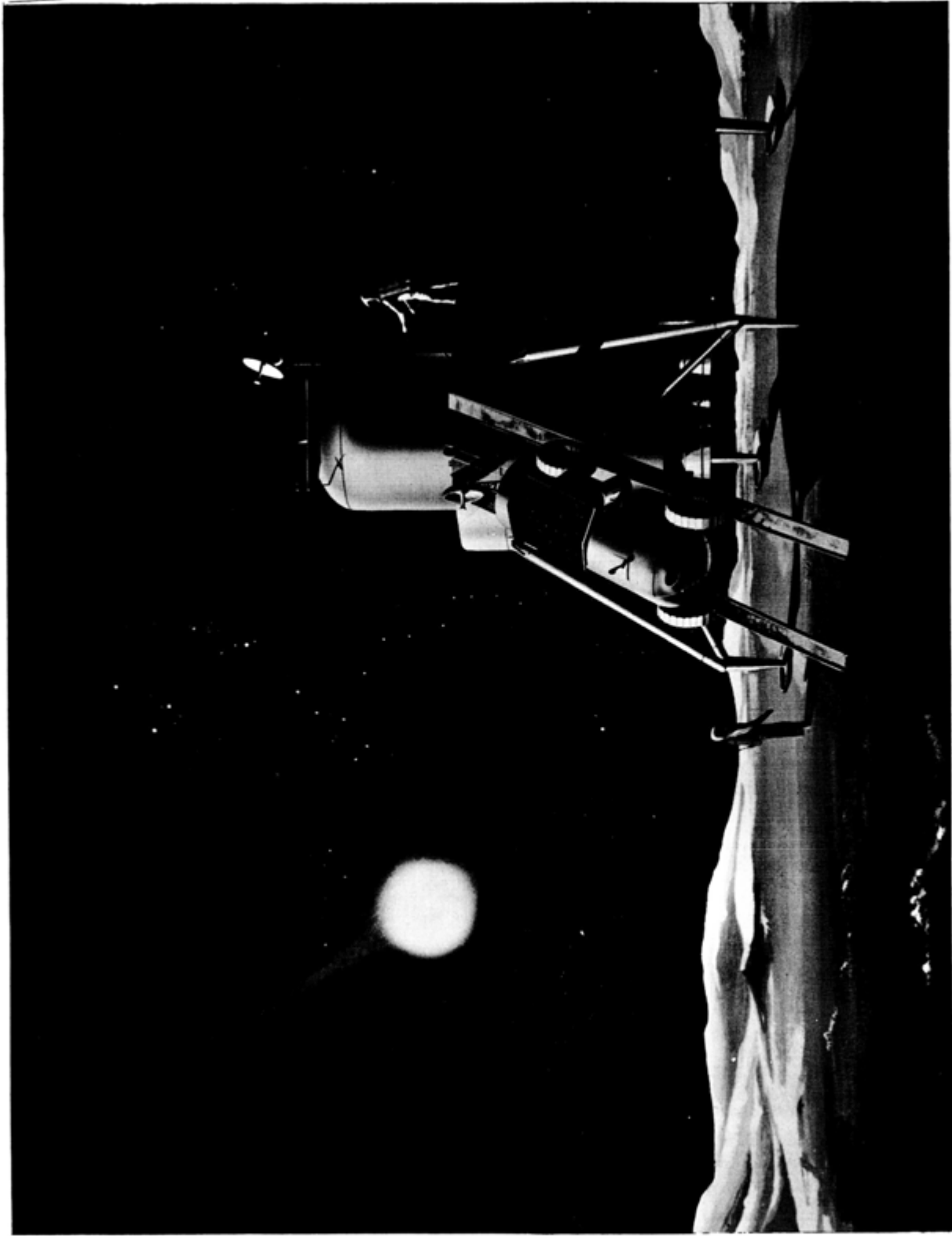

FIGURE 25. LUNAR EXCURSION MODULE WITH THE LUNAR ROVING VEHICLE ON THE LUNAR SURFACE  
(ARTIST'S CONCEPT)

This program is planned to be used in conjunction with future test programs to establish the heat transfer coefficients on deflector plate surfaces. It is also hoped that the program will prove effectual in determining model scaling relationships, thus enabling the amount of testing presently required to be significantly reduced.

## I. OVERWATER JET IMPINGEMENT.

This study was initiated during the past fiscal year as part of the efforts of this branch to investigate new methods for launching future space vehicles. The program is a direct outgrowth of the predicted shortages of available real estate and subsequent high costs for future launch facilities.

Two parallel and closely related studies are in effect to determine the important parameters associated with overwater launch complexes.

One study, which is being conducted by the Test Division, MSFC, is the overwater testing of model engines. From these tests, valuable information will be obtained.

The second effort is a mathematical analysis of the test results in order to derive supporting theoretical design formulas.

With both test data and supporting calculations in hand, it may become possible to accurately develop preliminary design criteria for large thrust vehicle engines in order to evaluate the feasibility of future overwater launch facilities.

## NOTE

As FY 1964 unfolds, other in-house study programs will be initiated to meet the changing requirements to be placed on the Launch Operations Center. Flexibility and Multiplicity of effort on the part of the Future Studies Branch will be continued so that it will be able to fulfill its comprehensive support role to the national space program.

SECTION X  
LAUNCH OPERATIONS CENTER OUT-OF-HOUSE STUDY PROGRAMS  
FISCAL YEAR 1963

A. LAUNCH UMBILICAL TOWER (LUT) CONNECTIONS AT THE PAD.

This study investigates the uses of disconnect panels for coupling electrical, pneumatic, hydraulic, air-conditioning, and other systems to determine the suitability of disconnect panel applications for the LUT launch concept.

The mobile launch concept requires quick, reliable, and economical mechanical and electrical connectors to assure efficient and successful launch operations. Provisions for automatic connect and disconnect capability between the LUT and pad can also decrease operational time.

Because of the planned increase in launch rates to support various programs, it has become important that the launch pads be occupied for the least time possible. This study should indicate that several days of preparation time can be reduced to several hours.

B. METAL EROSION OF SOLID PROPELLANT JETS (SPREE).

Launching of large solid propellant boosters introduces new launch facility requirements due to the high erosive effects of the solid particle content of the exhaust. This study is being conducted in conjunction with a suitable test program to optimize flame deflector design concepts for attenuating the rocket exhaust gases, and to develop an economical method for protection of those components of the launch facilities exposed to the exhaust stream as the vehicle ascends.

The purpose of this study is to determine shapes and materials to withstand the detrimental effects of solid propellant jets on launchers and associated equipment. This preliminary work studies the effects of large solid jets for relatively low lift-off acceleration rates, and is providing promising shapes and materials. A later study will be concerned with detailed design problems, based on criteria and requirements established by solid propellant vehicle configuration studies.

This study supports MSFC solid vehicle studies and launch facility studies for solid boosters. It is a necessary study to prepare for launching solid propellant vehicles at AMR.

The Future Projects Office of MSFC is funded for study of solid propellant launch vehicles. This study will aid in the elimination of the basic launch problems created by solid propellant motors.

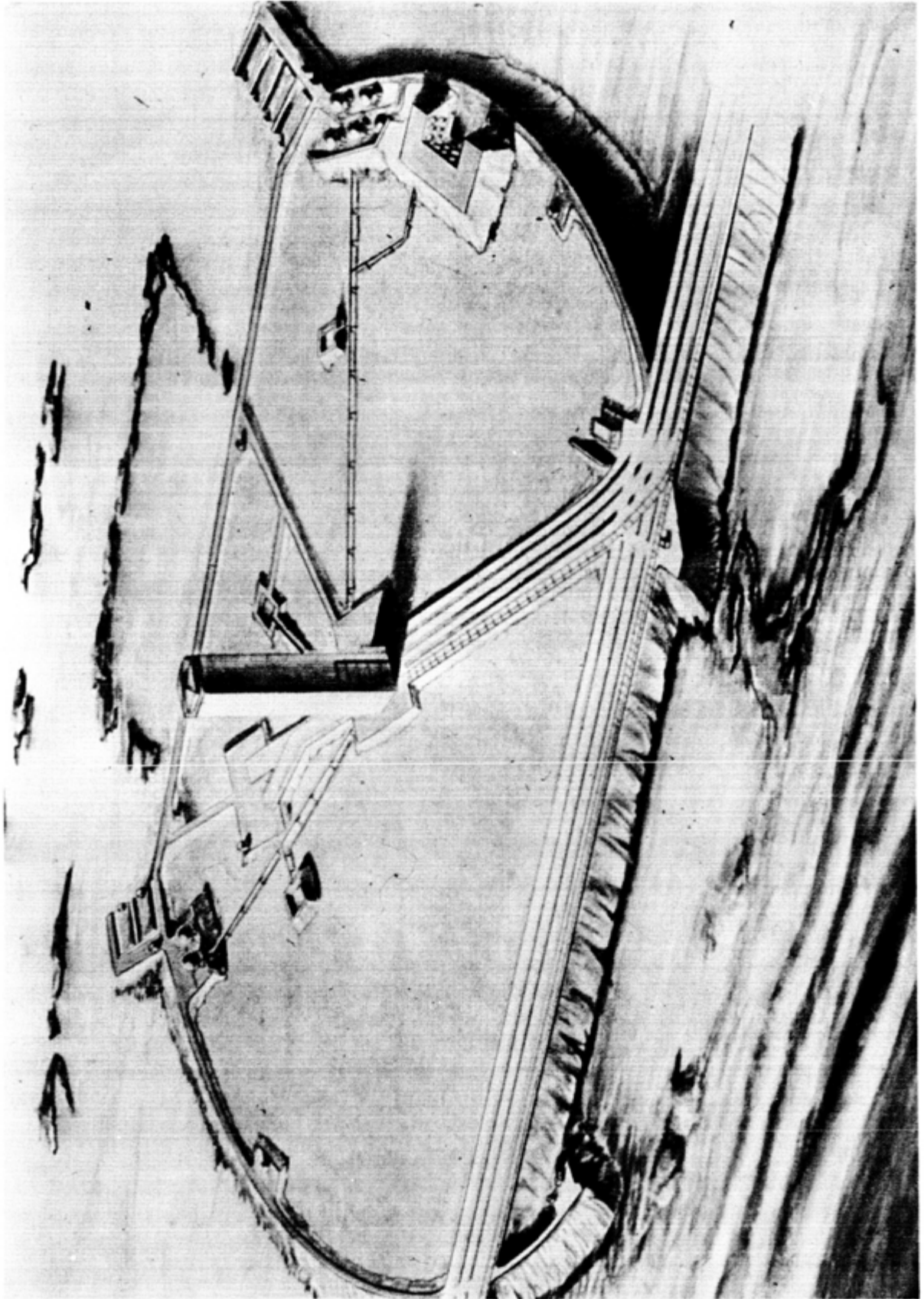

FIGURE 26. NOVA PAD AREA WITH LAUNCH BUILDING (ARTIST'S CONCEPT)

### C. JET IMPINGEMENT ON WATER.

The purpose of this study is to perform analytical calculations and model test evaluations to obtain scaling laws and design parameters applicable to overwater vehicle launchings. Consideration is being given to the various conditions that may exist, such as: a restricted body of water, a large body of water, water depth, and the possible use of a rigid underwater flame deflector. This study contributes to the basic research for the adverse conditions that exist when launching a vehicle over water. Prior approval has been initiated, and considerable funds have been expended without a completed program. The basic research obtained from this study may have direct use with the NOVA program, dependent upon the selection of the final NOVA configuration.

### D. RESCUE AND ESCAPE SYSTEMS.

As space vehicles become larger, they require taller service structures, which increases the problem of personnel safety. Protection methods are needed to provide safe, rapid egress of personnel from these tall structures in the event of a catastrophe. The use of stationary protective devices may also be utilized to provide reasonable personnel safety.

### E. NOVA LAUNCH FACILITY STUDY.

The purpose of the initial phase of this study will be to develop major launch complex facilities requirements and concepts for the most promising candidate vehicle concepts developed by the vehicle system study contractors. These requirements and concepts will be developed to the extent necessary to identify any critical facility requirements which could influence the final selection of a NOVA vehicle configuration. Operational requirements, cost, availability, and reliability factors will be considered in identifying these critical areas. The second phase of this study will be an extension of Phase I in sufficient detail to clearly establish and define the optimum concept for the selected NOVA vehicle configuration. This phase of study effort will provide sufficient additional data and preliminary design details for the selected concept from which final design criteria for all major facilities and ground support equipment may be developed. Results will include a general layout of the system complex, conceptual layout of the major facilities and required transportation media, definition of preliminary criteria, and complete analysis of such elements as construction procedures and schedules, special logistical support requirements and overall logistics plan, safety provisions, environmental control, construction costs, and operating costs.

This study parallels the NOVA vehicle study being conducted by the Marshall Space Flight Center. An optimized NOVA system can be determined only if adequate and specific facility requirements are also considered in the system.

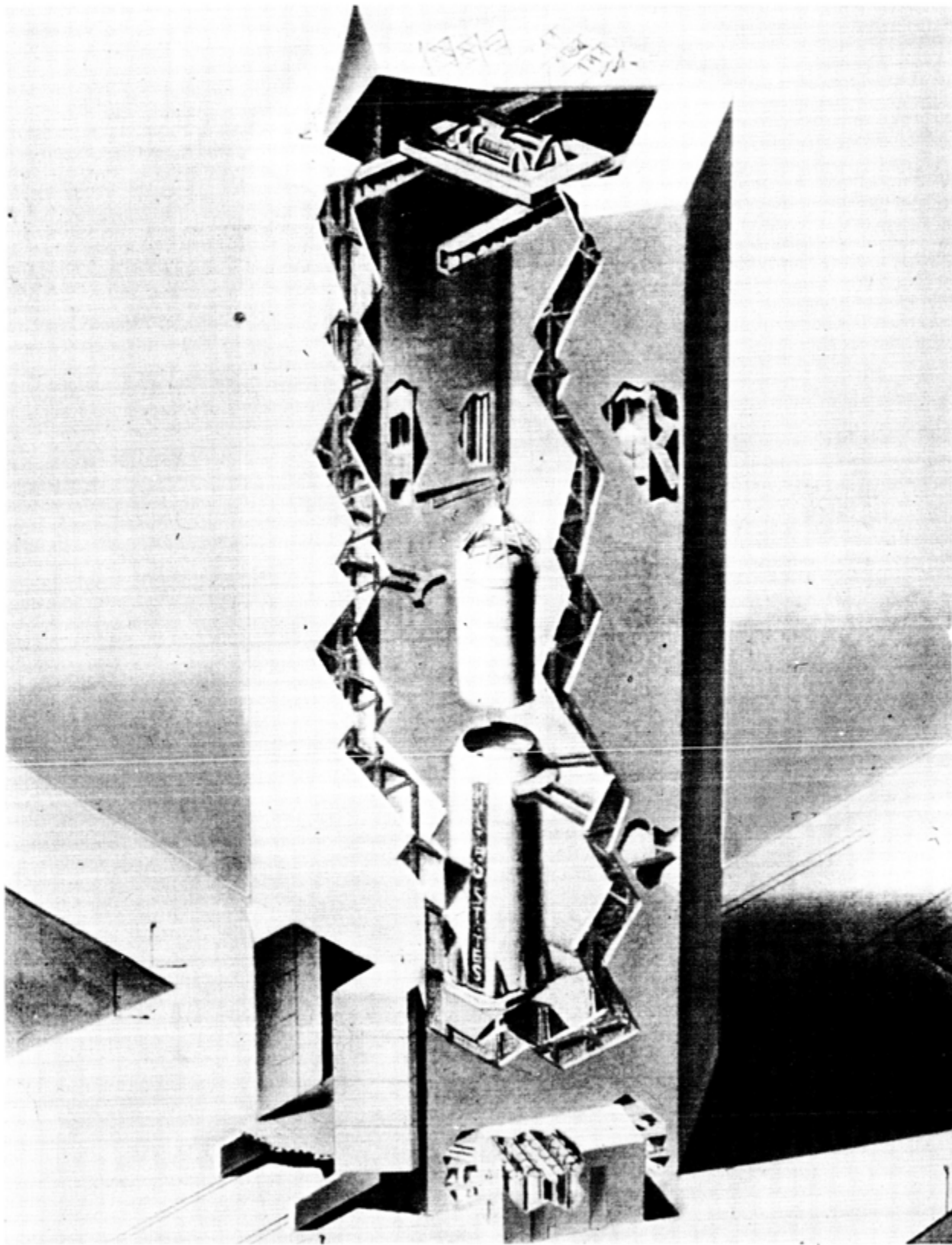

FIGURE 27. NOVA LAUNCH BUILDING (ARTIST'S CONCEPT)

SECTION XI  
LAUNCH OPERATIONS CENTER OUT-OF-HOUSE STUDY PROGRAMS  
FISCAL YEAR 1964

A. FACILITY CONCEPTS FOR LARGE THRUST VEHICLES.

This study will develop concepts for launch complex support equipment and facilities for large thrust vehicles and will be divided into two parts. The concepts must be sufficiently developed in Part I to assist in the selection of a final large vehicle configuration. Operational requirements, costs, availability and reliability factors will be considered.

Part II will continue the study along more specific lines of investigation, evaluation, and preliminary design to establish and define the optimum facility concept for the selected large vehicle. Selection of the optimum concept must be based on a comprehensive analysis of operational requirements, reliability, availability, schedules, costs, safety requirements, logistics, land area requirements, and environment.

Sufficient data and design details will be provided to permit the development of the final design criteria for all major launch facilities and ground support equipment.

B. LEAK DETECTION METHODS.

A major problem in present prelaunch operations is leak recurrence. Leaks have been known to be induced in various systems each time a flight vehicle is repositioned, reoriented, or static fired. Present leak detection methods are confined to measurements of pressure drop, halide detectors, and bubbling solutions for visual inspection. These methods are considered marginally adequate in the scope of present earth launch operations and limited in flexibility.

Future operations will require other leak detection methods to achieve goals of reduced checkout and detection time in the limited access systems frequently encountered in space vehicles today. This study will place primary emphasis on the conceptual design of an automated prelaunch leak detection system for a typical space vehicle stage. Secondary emphasis will be placed on the adaptation of on-board hardware to an automated system compatible with and operable in a space environment.

C. REDUCTION OF LH<sub>2</sub> BOILOFF RATES.

This study will investigate various techniques of reducing LH<sub>2</sub> boiloff losses, and will provide design criteria for accepted methods of loss reduction. Reduction in boiloff losses will yield significant savings in propellant and equipment costs.

Future planning of MSFC encompasses large vehicles using hydrogen-fueled engines. With this trend, the problem of LH<sub>2</sub> boiloff becomes more significant.



Present NOVA studies indicate expected boiloff rates up to 12 percent per hour. This, combined with possible fueled holds of up to 12 hours, will yield fuel evaporation losses at the pad of over a million pounds for NOVA class vehicles. Pipelines, valves, and pumps must also be sized to compensate for boiloff losses.

#### D. HELIUM USE AND REUSE TECHNIQUES.

The purpose of this study is to provide a development and testing program for high pressure - high flow rate flexible hoses and couplings. This study will examine the most economical techniques and methods for using gaseous and liquid helium. Helium is not only expensive, but is in limited supply. Strict control over the use of this gas in purging and pressurizing space vehicle systems is therefore mandatory. The increasing vehicle demands for helium make a close examination of various methods of conserving this critical gas necessary. This study will determine acceptable substitutes for helium, define minimum uses in systems where no substitution can be made, and examine practical reclaiming methods that can be applied to space vehicle systems.

#### E. ADVANCED LAUNCHER AND DEFLECTOR RELATED STUDIES.

The purpose of this study is to determine the requirements and designs of launchers and deflectors for NOVA and post-NOVA class vehicles. Specific requirements will depend on vehicle configurations selected from current and planned studies. For instance, a NOVA solid booster (especially if center supports were used) would present grave problems in launcher and deflector design and materials by impingement of aluminum particles in the jet stream; or a plug nozzle concept would require radical changes in launcher concepts and configurations. The addition of wings for recoverable boosters will probably necessitate changes in launcher designs, and also may influence deflector placement and design.

#### F. SPECIAL LAUNCH SUPPORT EQUIPMENT AND FACILITIES REQUIRED FOR FUTURE MISSIONS.

The purpose of this study is to define in detail the launch support equipment and facilities for launch operations for 2-1B and SATURN V equivalent solid propellant vehicles. The purpose of this study is to define additional facilities and ground support equipment that will be required at the MILA to fulfill orbital and lunar missions. These requirements will be more fully indicated when orbital and lunar missions are further defined. Special ground support equipment and facilities will probably include, but will not be limited to, a system for subcooling lox and LH<sub>2</sub> storage and pumping facilities for storable propellants and packaging equipment for items to be transported. Facilities for storage of the fluorine or boron type with also be included.

#### G. CRYOGENIC PROPELLANT STORAGE AND TRANSFER TECHNIQUES.

The purpose of this study is to generate and evaluate new methods of cryogenic storage and transfer. Lox, LH<sub>2</sub> (possibly subcooled), and fluorine will probably be used and transported in large quantities for orbital and lunar missions. This study will investigate methods of storing and transferring these cryogenics in earth orbit, on the moon, and at AMR, and provide detail design data and criteria based on requirements.

to be further defined. Insulated flexible lines and expansion joints will also be studied.

#### H. HIGH PRESSURE, HIGH FLOW RATE FLEXIBLE HOSES AND COUPLINGS.

The purpose of this study is to provide a development and testing program for high pressure flexible hoses and couplings suitable for loading various chemicals on board space vehicles at high flow rates. Because of the unique fluid handling demands of present and future space vehicles, special flexible hoses and couplings are required that are not generally available from industrial suppliers. Reliable flexible hoses and associated hardware must be developed to handle cryogenic fluids, gases, and possibly exotic propellants such as fluorine- or boron-based fuels.

#### I. IMPROVED LAUNCH SITE ASSEMBLY AND CHECKOUT TECHNIQUES.

The purpose of this study is to minimize the time consumed for assembly and checkout of launch vehicles. Methods for shortening the time required for assembly and checkout with conventional facilities will be studied. New concepts for launch site assembly and checkout will be generated and evaluated. Also, the new mobile launch concept requires that remote control of all ground support equipment be investigated to provide safe, reliable operations during launch.

This study will support the mobile launch concept, increase the integrity of assembly and checkout techniques, and reduce time required for assembly and checkout. Specifically, it will help meet the requirements imposed by the decreasing limits of launch windows for space missions.

#### J. FACILITIES FOR SOLID PROPELLANT VEHICLES.

The purpose of this study is to define in detail the launch facility requirements and launch operations for S-IB and SATURN V equivalent solid propellant vehicles. Earlier studies will determine the most feasible launch concept for large solid propellant vehicles and the most feasible large solid propellant vehicle configurations. This study will detail the selected launch concept with appropriate design criteria based on the selected vehicle configuration requirements.

This study is a necessary step to establish a complete launch vehicle program for large solid propellant boosters. The MSFC studies would be incomplete and unusable without the proper launch concepts to support the vehicle system and total mission.

#### K. LAUNCH FACILITIES FOR ORBITAL OPERATIONS.

Future orbital operations will place new and unique requirements on the Launch Operations Center facilities. The various payload configurations and densities combined with tight launch windows and precision trajectory requirements will necessitate new and versatile launch facilities and operations. The purpose of this study is to investigate the impact of orbital operations on LOC and develop equipment and operating procedures to permit a reliable and successful orbital program.

SECTION XII  
SELECTIONS FROM THE PLANNED STUDY PROGRAMS  
FISCAL YEAR 1965 AND BEYOND

**A. SPECIAL SOLID PROPELLANTS HAZARDS ANALYSIS.**

Large solid boosters have storage and launch hazards peculiar to themselves. Safe handling and storage methods are required to prevent catastrophic accidents and to maintain booster reliability. One particular area needing close investigation is the toxicity of the exhaust gases and the effects on launch personnel, equipment, and the uncontrolled civilian populace. The study will define special solid propellant hazards and recommend safe operating procedures and equipment.

**B. LAUNCH PROBABILITY ANALYSIS.**

The purpose of this study will be to devise methods whereby the expected launch probability of future space vehicles of any given type or class can be predetermined. The methods devised shall consider the fabrication, assembly, checkout, transportation, prelaunch checkout, erection, countdown, and launch phases of a vehicle. Further, the study shall consider in sufficient detail all outside influences which may directly or indirectly affect the launch probability of the vehicle class under consideration from the successful launch of the vehicle to fully completing its mission.

Planning of future space missions will be greatly aided by having prior knowledge of the probability that any vehicle configuration under consideration can be launched within a specified period in time (launch window).

**C. HIGH-PRESSURE GAS STORAGE, TRANSFER, AND UTILIZATION TECHNIQUES.**

SATURN V, NOVA and post-NOVA launches will require tremendous quantities of helium, nitrogen, and hydrogen gas. The storing of large gas quantities and transferring them at very high flow rates will be expensive. Large potential cost savings may be realized by a comprehensive study to optimize storage and transfer techniques.

An extensive investigation is also required to determine the most effective, reliable, and least costly methods for gas storage in orbit for orbital launching operations.

**D. REDUCTION OF VEHICLE AND GSE ELECTRICAL AND MECHANICAL TOLERANCES.**

Close tolerances are expensive. A fine tolerance that is unnecessary does not improve the equipment. Huge costs are associated with the mechanical and electrical tolerances called for in the construction and launch of a space vehicle. A concentrated

study to reduce unnecessarily close tolerances on vehicle and ground support equipment can yield a significant savings potential.

#### **E. FIRING ACCESSORIES AND UMBILICAL CONCEPTS.**

The increasing size and complexity of space vehicles have been causing proportionate changes in firing accessories and umbilical equipment. Because of the growing cost of these items, a detailed examination of possible alternate concepts is required. This study should reveal new, reliable, and economic firing accessories and umbilical concepts.

#### **F. ALTERNATE LAUNCH SITE STUDIES.**

Increasing space vehicle size, nuclear stage development, the possibility of toxic fuels, and the need for numerous pads to meet high launch rates will demand large acreages for launch site construction. This demand may exceed the geographic limits possible for AMR.

This study will examine the costs, logistics, and growth potential of selected alternate land-based launch sites within and without the continental United States, to select one or more attractive launch sites to supplement AMR.

#### **G. INVESTIGATION OF INITIAL ORBITAL LAUNCHING FACILITIES.**

The purpose of this study is to investigate various methods and requirements for launching a vehicle from an orbiting space station, and to determine preliminary orbital launch equipment and facility designs.

#### **H. INTEGRATION OF SPECIAL NUCLEAR STAGE REQUIREMENTS ON LAUNCH FACILITY AND OPERATIONAL PLANS.**

The purpose of this study is to identify and plan for the special facilities, equipment, and operations required to support a nuclear staged space vehicle. The development of a nuclear assembly building for reactor engine assembly and integrated checkout procedures for the nuclear stage must be planned at an early date. Preliminary study efforts are required in the areas of failure effect analysis for all conceivable launch modes, engine assembly, handling and checkout requirements. Definition of remedial procedures for postulated accidents must be made.

#### **I. FACILITY REQUIREMENTS FOR RECOVERABLE BOOSTERS.**

The large boosters that will be required for SATURN V and NOVA space vehicles are extremely costly. Techniques are being developed to recover the expended boosters and return them for refurbishment.

A facility will be required that will quickly and inexpensively process recovered boosters to "factory fresh" condition. This study will define booster refurbishment

equipment, operations, and costs, and supplement an MSFC study on booster recovery, and will also provide a cost and conceptual input to the program.

#### **J. FEASIBILITY OF OFFSHORE LAUNCH FACILITIES FOR LARGE VEHICLES.**

Launching facility requirements for large space vehicles may soon exceed the land limits of Cape Canaveral. It is also possible that offshore launch facilities for future vehicles would be more advantageous technically and economically than land-based facilities. Present studies indicate that populated areas may be within the hazardous limits for NOVA class vehicles at AMR. This study will determine the feasibility of launching large vehicles from offshore facilities.

#### **K. COMMUNICATIONS AND TV CAMERA CONTROL SYSTEM STUDY.**

To determine the feasibility of and, if feasible, to provide design and cost estimates for a complete system of remotely controlled TV (closed circuit) cameras at strategic locations around the launch complexes. These cameras are to be capable of control from the LOC Information Center Console, and their signals are to be capable of mixing with presently available signals from fixed cameras and audio nets for distribution to remote locations at Cape Canaveral, Huntsville, Washington, Houston, et cetera.

This system will increase the capacity of the information center already installed (or being installed) by allowing for selection of video scenes on demand whether previously planned or not. For example, at the request of an observer in Washington, a camera in the blockhouse could be energized and focused on a particular panel allowing the display on that panel to be read in a display room at NASA Headquarters. This will greatly increase the value of the system in providing detailed knowledge of actual launch operations.

#### **L. SERVICE STRUCTURE CONCEPTS STUDY.**

The purpose of this study is to investigate new service structure concepts and methods of modifying service structures to increase versatility and operational capability of such structures. This project will provide studies of enclosures, methods of increasing height of service structures, new structural and structure transport methods, and servicing platform mechanisms to obtain optimum modes of construction as measured by both cost and allotted time availability.

This study will support changing vehicle configurations created by the many different payloads and mission requirements, and thereby decrease the cost of launch facilities. It is extremely difficult to change the present service structures to actively support more than one vehicle configuration, and this study will investigate methods by which several vehicle configurations could be serviced by the same structure without extensive operational preparation.

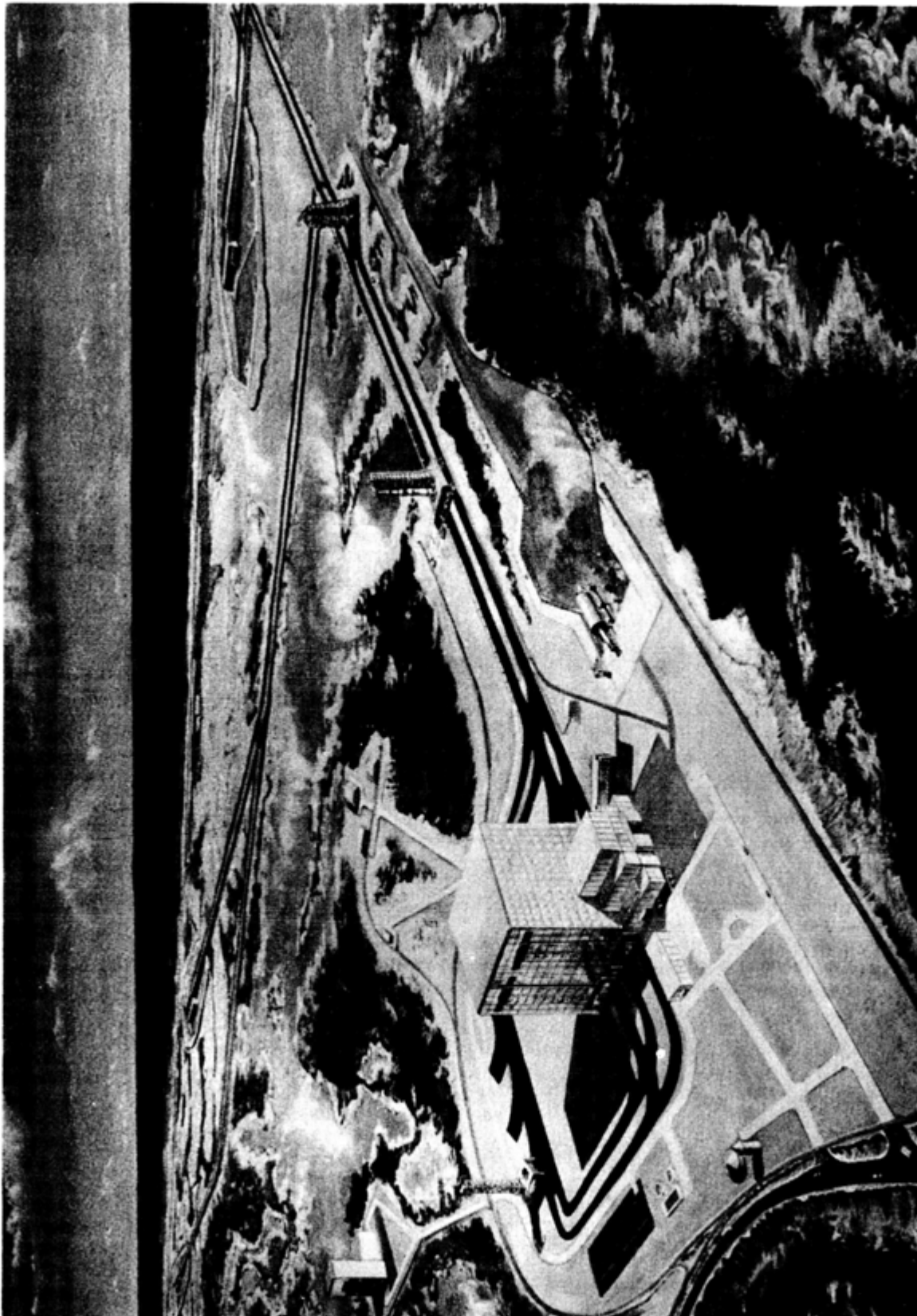

FIGURE 28. LAUNCH COMPLEX 39 CONCEPT

SECTION XIII  
SELECTIONS FROM PAST STUDY EFFORTS  
FISCAL YEARS 1960, 1961, AND 1962

A. PROPOSED LAUNCH FACILITIES STUDIES.

1. C-3 and NOVA Facility Concepts - Fixed versus Mobile. Considerable effort was expended toward providing the technical direction and guidance required for the development of C-3 and NOVA launch facility concepts, cost estimates, and schedule requirements. This effort came in response to a letter from the Associate Administrator, NASA, which requested the Director, Launch Operations, and the Commander, AFMTC, to analyze launch requirements for an early manned lunar landing program. Launch facility concepts for both liquid- and solid-propellant booster vehicles of the SATURN C-3 and NOVA configurations were established. Different launch facility requirements to meet different launch rates were considered (Fixed versus Mobile) as well as off-shore and on-shore concepts for the NOVA class vehicles.

Basically, the C-3 facility consists of a vertical assembly building, three launch pads, and a connecting track system. The vehicle is assembled on a mobile launcher/transporter in the off-pad vertical assembly building, and is then moved in a vertical position to the above grade launch pad by means of the connecting rail system. The umbilical tower is an integral part of the launcher/transporter which permits this movement to be accomplished without breaking the umbilical connections. Final checkout, prelaunch operations, and launch are controlled through a digital link between a computer on the launcher/transporter and one in the launch control center at the vertical assembly building. Each pad has an independent propellant storage and transfer system.

The NOVA on-shore facility concept consists of three fixed vertical assembly and launch buildings and a launch control center area. The vehicle booster is transported through a canal system to the building on a launcher/barge, which is then secured to the building structure to serve as a launcher. The upper stages of the vehicle are assembled and checked out in the vertical assembly and launch building. Final checkout, prelaunch operations, and launch are controlled through a digital link between a computer in the launch building and one in the launch control center. The vehicle is then launched from within the fixed structure through the open roof.

Off-shore launch facilities developed for NOVA are quite similar to the on-shore facilities with the obvious exception of the foundation structure. One proposed method for supporting such a structure above water would be on clustered pilings. Access to this structure is gained by water-borne vessels and by causeways. Again, a digital link connects the off-shore facility with the on-shore launch control center. (Ref. Report No. MIN-LOD-DL-3-61, August 1, 1962, "Preliminary Concepts of Launch Facilities for Manned Lunar Landing Program," by O. L. Sparks, for further details).

2. Launch Facility Requirements for the C-4 Space Vehicle. Following the study efforts described in the C-3 concept study above, the entire vehicle program was re-oriented to the C-4 vehicle configuration, and included consideration of solid and nuclear stages. A complete reevaluation of launch facility requirements including cost estimates and scheduling was made in the light of this vehicle change. Fixed versus Mobile launch facility concepts were thoroughly evaluated from a reliability, safety, availability, and growth potential standpoint. Operational modes of transfer for the mobile concept were thoroughly evaluated for both the rail concept and the canal versions. For further information on these study results, reference Report No. MIN-LOD-DL-6-61, October 27, 1962, entitled "A Preliminary Study of Launch Facility Requirements for the C-4 Space Vehicle."

3. Equatorial Launch Sites. The purpose of this investigation was to systematically search out all available data on possible equatorial launch sites, to correlate and evaluate this data in relation to present and anticipated requirements in the space program, and to develop a system that will permit ready determination of cross-over points in making trade-offs between operational, economical, and mission requirements for both medium and high thrust space vehicles. The results of this study were placed in a reference manual and will provide answers to the following questions:

- a. What launch base concepts offer the most advantages?
- b. Which equatorial launch site is most economical?
- c. What are the economical and operations trade-offs for an equatorial site?
- d. For what type missions does an equatorial launch site become a critical factor?
- e. Under what conditions (mission requirements, economics, operational requirements, etc.) is an equatorial site justified?

4. Optimized Land Based Facilities. Based upon requirements for high sustained firing rates of one vehicle launch per week and salvo orbital launching of 6 to 7 vehicles in a three-week period, it became necessary to conceive and develop new concepts for launch complex configurations and checkout procedures, and concepts for the optimum utilization of these facilities and existing Cape real estate. These concepts were in addition to the facility requirement for SATURN I, which is represented in the artist concept of Complex VLF 37 shown pictorially in report No. MIN-LOD-DL-1-61, a summary of the results and findings of this study effort.

5. Land Expansion Study. With the advent of more and larger space vehicle systems, real estate availability at the Cape is becoming a serious matter for concern. In anticipation of the needs for the future, this branch prepared a proposed statement of work for a "Cape Canaveral Land Expansion Study" and forwarded it to LOC for comments and coordination with AMR officials.

6. Effects of Jet Impingement on Water. In the development of new launch facilities for space vehicles to be employed in the manned lunar landing program, it was necessary to consider many new concepts. Some of these concepts involve overwater launching with the rocket engine jets impinging on a body of water. The characteristics of this body of water may vary from a large unrestricted volume, in the case of off-shore facilities,



to a relatively small restricted volume, in the case of a land-based facility utilizing canals and locks. The use of low cost waterbarge access to overwater facilities plus the advantages of jet exhaust attenuation in a self-healing body of water appeared sufficiently attractive to justify a thorough investigation of the problem areas involved to determine the feasibility and critical design parameters for such facilities.

7. Off-Shore Launch Facilities Studies. The advent of crowded conditions at the various launch facilities, large propellant storage requirements for multi-staged vehicles, higher firing rates, nuclear propelled stages, and safety considerations introduced the concepts of off-shore and semi-off-shore launch facilities. Considerable in-house efforts were made in this area and prospective bidders for studies were oriented on study requirements. The results of the in-house efforts are discussed in Report No. IN-LOD-DL-6-61, "Off-Shore Facility Study," by O. L. Sparks.

8. Modifications Required on VLF 34 for SATURN C-2 Vehicles. The most exacting mission requirements of the SATURN C-1 space vehicle introduced the need for a larger thrust SATURN vehicle called the SATURN C-2. To utilize existing facilities at Complex 34, a feasibility study was made to determine the necessary modifications to Complex 34, and cost requirements which would permit the launching of C-2 vehicles. Results of this study were published in Confidential Report No. IN-LOD-DL-2-60, by O. K. Duren.

## B. GROUND SUPPORT EQUIPMENT STUDIES.

1. Barge Launcher/Transporter Concepts. Considerable effort was expended toward detailed evaluation of the barge approach to the mobile launcher/transporter concept. Assistance was received in stability and propulsion analysis from a Naval Architect Consultant. Additional effort was expended by the David Taylor Model Basin in a model test program funded through this office. Results of these studies may be made available upon request.

2. Crawler Concepts. After review and study of barge, rail, and crawler transporter/launcher concepts, it was concluded that the crawler concept was the most desirable from a monetary, availability, and operational standpoint. The feasibility of this concept was further verified through a detailed study contract awarded to the Bucyrus - Erie Company. This company was selected to prepare this study because of their past experience in designing and manufacturing crawlers as well as other means of moving heavy mining and excavating equipment. The weights supported by commercially available crawlers developed for large excavating machinery is greater than the estimated weight of the SATURN C-5 transporter. They have the advantage of low bearing pressures, resulting in economical road construction; and automatic hydraulic leveling and hydraulic steering systems which insure proper handling of the space vehicle. In addition, electrical systems have been developed to give accurate and reliable control of the extremely high torques and accelerations encountered in other motions in large excavator service. These systems can be readily adapted to the problem of controlling acceleration and deceleration of the launcher under a wide variety of conditions resulting from wind and grade. This detailed study considers the feasibility of utilizing available crawlers and

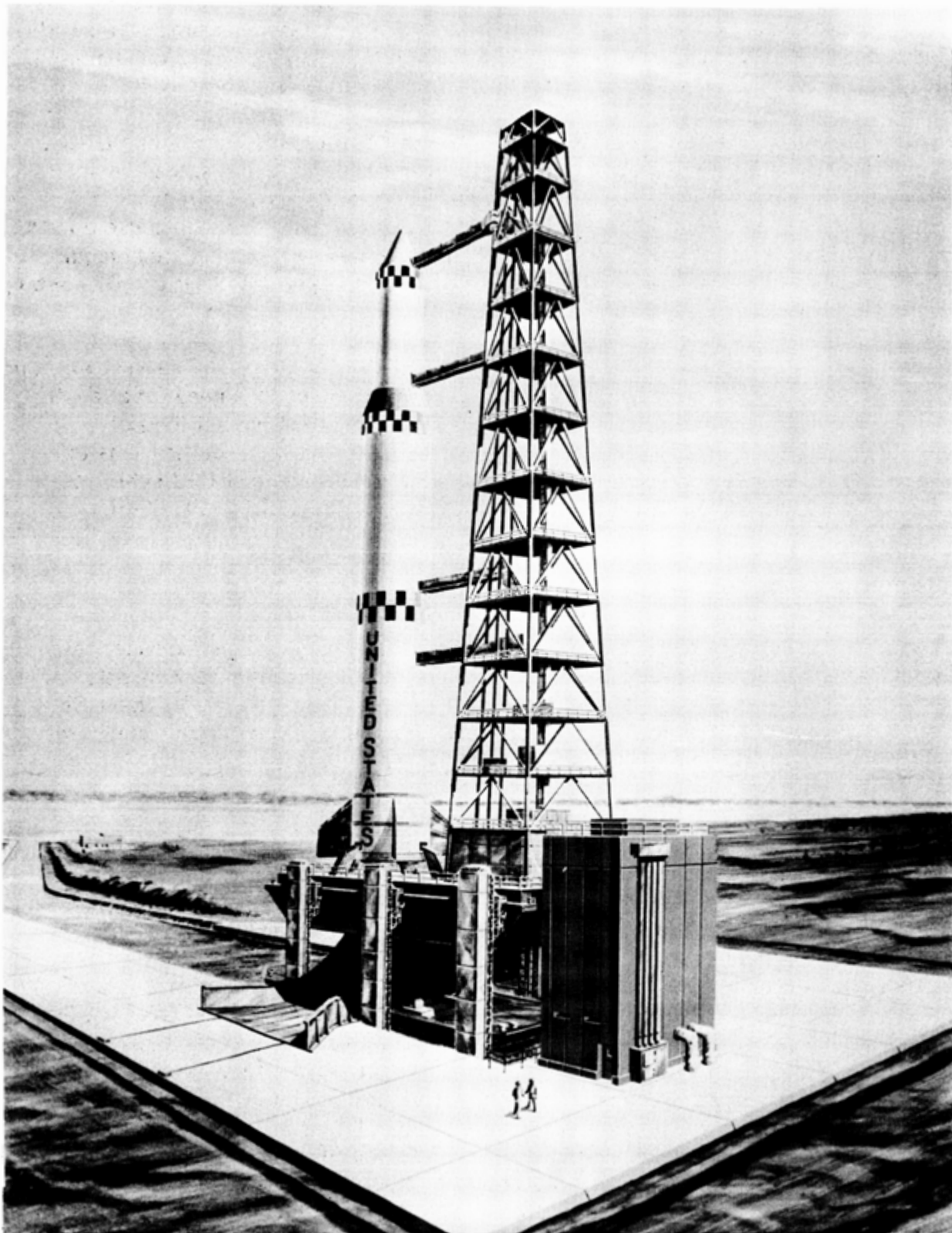

FIGURE 29. SATURN MOBILE LAUNCHER/TRANSPORTER-BARGE  
(ARTIST'S CONCEPT)

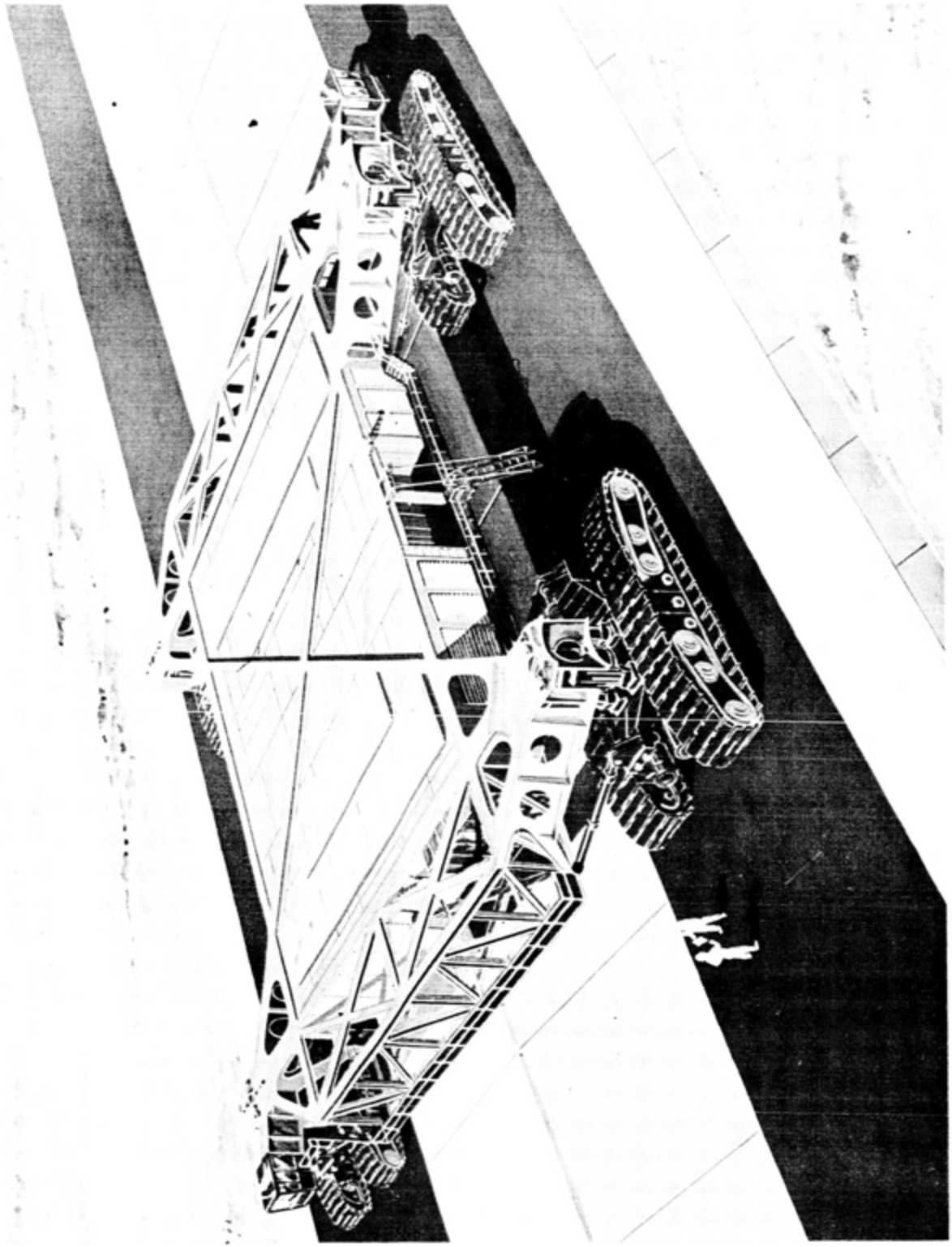

FIGURE 30. ARTIST'S CONCEPT OF LAUNCH COMPLEX 39 CRAWLER

determines what modifications would be required. The parameters for roadways under the various conditions which may be encountered are established, along with cost estimates for the structural portions of the transporter and crawler. As the study progressed, modifications were suggested indicating that an independent crawler transporter carrying a detachable launching pad might be practical.

### 3. Evaluation of Parameters Related to the Design of the C-1 Flame Deflector.

The high thrust rocket engines used in present-day missiles and space vehicles release large quantities of energy in the form of exhaust gases. These high-temperature, supersonic, velocity exhaust jets create serious hazards to personnel, structures, ground support equipment, and instrumentation at the launch sites. The continuing trend toward larger and higher thrust engines, with the concomitant increase in hazards, makes it essential that accurate methods be established for predicting and controlling the exhaust jet effects.

The quantity and distribution of the exhaust jet energy depends on several variable factors. The total energy available is determined by the type and amount of propellant used. The form and rate of energy release is controlled by the rocket engine design and the design and the number of engines, and distribution of the energy in the area surrounding the launcher is controlled by the exhaust flame deflector design. Since the magnitude of the first two of these variables is determined by the vehicle design criteria to meet given mission requirements, the flame deflectors must be designed for controlled deflection of a predetermined amount of energy at the launch site. In study efforts directed toward this subject, various types of deflectors were discussed, and the general design criteria for an uncooled heat-sink type deflector was developed. This criteria is applicable to a broad range of thrust levels which include the booster systems of space vehicles to be developed in the foreseeable future. Although theory has been developed and is of significant value in designing flame deflectors, it should not be construed that the theory provides all necessary design information, rather the theory must be supplemented with an extensive model test program.

The successful launching of the first SATURN I space vehicle provided additional verification of the design criteria developed for the uncooled flame deflector. For additional information, refer to report No. MIN-LOD-DL-5-62, "Launch Deflector Criteria and Their Application to the SATURN C-1 Deflector," by R. L. Evans and O. L. Sparks.

### 4. Deflector Configurations for Liquid C-3 and NOVA Configuration.

Considerable effort was directed toward the investigation of above- and below-ground deflector configurations for diverting and attenuating the exhaust jets of liquid-fueled booster vehicles of the C-3, C-4, C-4N, and NOVA vehicles. A variety of design configurations capable of handling the above vehicles were developed. Emphasis was placed on the use of dry deflectors since maintenance and repair costs are substantially lower than the fixed costs associated with wet deflector configurations. However, a wet deflector concept is presented for use with the NOVA vehicle since other considerations, such as acoustical attenuation, pad location, extended holddown period, availability of coolant, etc., may impose additional deflector design considerations. Materials of construction include reinforced concrete, structural steel, mild steel, or a combination thereof. Provisions

for the repair or replacement of all deflector configurations are also considered. For further information, reference report No. M-LOD-DL-5-61, September 18, 1961, "Flame Deflector Configurations Required for the Attenuation of Exhaust Jets From C-3, C-4, C-4N, and NOVA Space Vehicle Boosters," by R. L. Evans.

5. SATURN Ground Support Equipment Handbook. A handbook covering all major SATURN GSE was edited, published, and released through this office. Graphic illustration and art work was performed for this publication.

6. Ground Facility Requirements for Subcooling Liquid Hydrogen. Effort was conducted to determine the feasibility of ground-subcooling large quantities of liquid hydrogen. This effort was necessitated by the possible requirements for subcooled liquid hydrogen payloads within the framework of the Orbital Operations Program. This study was conducted with a view toward providing the necessary piping, fittings, and subcooling equipment in the planned liquid hydrogen facility for the SATURN launch facility, complex 37, which will serve as a prototype for future SATURN/NOVA facilities.

Initial effort covered methods for achieving the desired degree of propellant subcooling, propellant transfer to the payload tanker, and the necessary ground support equipment for maintaining the propellant in the subcooled state during standby on the launch pad.

It was concluded that it is both practical and economically feasible to achieve subcooling in a spherical ground storage tank. A "cold" vacuum pump should be employed in the reduced pressure boiloff method. It was recommended that propellant transfer be accomplished at a flow rate which limits the overall propellant temperature rise due to pipe friction to approximately  $0.43^{\circ}\text{R}$  ( $0.25^{\circ}\text{K}$ ). This was determined to be approximately 2,500 gallons per minute for the particular propellant line proposed for Complex 37.

The ground support equipment requirements for maintaining the subcooled state will vary with mission requirements, degree of initial subcooling, and the heat transfer characteristics of the tanker during standby. If propellant temperature rise is excessive during standby, a liquid nitrogen shield or a mechanical refrigeration system based on the use of cold gas equipment was proposed to obviate the heat input into the tanker.

7. Advanced Complex 39 Concepts. Preliminary investigations were conducted toward development of a mobile arming tower concept for servicing and prelaunch pad operations required by the SATURN V vehicle. Such functions as installation and arming of solid propellant destruct and/or igniter systems, and last minute servicing of the manned payloads might be considered possible applications for such a system. Such a mobile tower could also be moved by crawler systems.

## C. ORBITAL AND LUNAR OPERATIONAL STUDIES.

1. Early Rendezvous and Docking Study. A design study was made for joining the payload of two test vehicles in orbit in a manner that they become a single unit. The



FIGURE 31. ARTIST'S CONCEPT OF A PAD FOR LAUNCH COMPLEX 39

purpose of this study was to define in detail a method of demonstrating orbital rendezvous at an early date using existing vehicles and technology.

2. Orbital Operational Plans. Periodic inputs are provided to the Orbital Operations Program in the form of preliminary design drawings and design analysis of such topics as orbital cryogenic storage tankers, propellant expulsion systems, super-insulation techniques, docking and coupling modes, couplings, and overall operational modes.

3. RIFT Program. Continuous support and coordination of the RIFT Program requires the performance of such functions as definition of facility and ground support equipment requirements, program scheduling and cost estimation, development of contractual statements of work and specifications for performance, proposal and contract review and evaluation, and monitoring of actual contract performance.

4. Leak Detection in Manned Spacecraft. All manned spacecraft must carry an air supply sufficient to provide for human needs and to maintain sufficient cabin pressure for the entire duration of an orbital or interplanetary flight. Since weight must always be kept to a minimum, great excesses of supply air and heavy leak detection equipment cannot be carried on board. Therefore, the loss of air through internal leaks or through an exterior skin of the vehicle, and the detection of such leaks must be considered a most serious problem. Meteoroids in space increase the probability of skin puncture, and the high external vacuum greatly increases the leakage flow rate through a puncture. Thus, a cabin leak must be quickly detected, located, and eliminated.

In addition to the manned capsule, special attention must also be given to the entire orbital launch vehicle and its associated propellant tankers. Past experience has shown that between pre- and post-static firings, a large number of leaks may develop in the pneumatic system of a booster or space vehicle. Thus, once in orbit, an orbital launch vehicle system will require extensive leak checkout prior to launch into outer space. Leak checks would be required for such items as propellant tanks, high-pressure storage spheres, pressurization lines, pneumatic couplings, tees, and joints.

It can be envisioned that two approaches to the leak detection problem are necessary: (a) A portable system may be required by the astronaut for external leak checkout of the manned space capsule and orbital launch vehicle systems in orbit, or at an orbital checkout station prior to launch into deep space. (b) An on-board fixed or semiportable system may be required during flight phases for detection of leaks in the manned capsule or in the orbital launch vehicle. Continuous monitoring and readouts from leak detection systems in both the manned capsule and orbital launch vehicle would then assist the astronaut in making a decision at any time regarding the nature of a leak, in determining the degree to which a leak will jeopardize his mission, and in establishing a criterion upon which to base a decision regarding the possible need to abort the mission and return to orbit for repair.

5. Earth Orbital Operations and Facilities. Continuous support was provided for the earth orbital operations program in the conceptual design of orbital cryogenic storage tankers and rendezvous techniques for refueling operations. At this time, the C-2 and C-3 SATURN vehicles were being considered for the lunar missions program. Preliminary



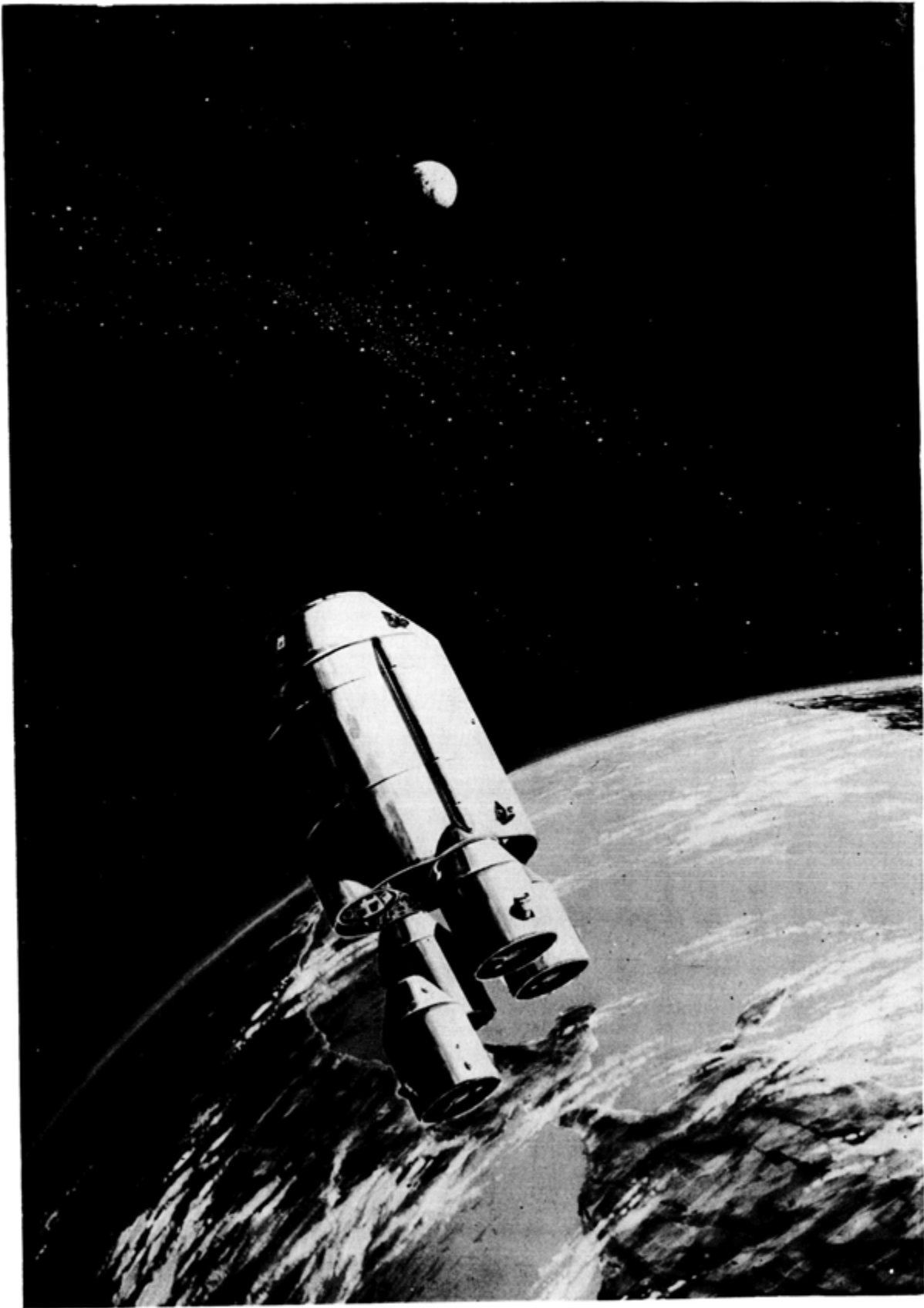

FIGURE 32. ORBITAL PROPELLANT DEPOT (ARTIST'S CONCEPT)



design details and supporting calculations for these studies are available in this office. Continued efforts will be directed toward these and similar concepts for support of future earth orbital operations programs and for the currently planned lunar orbital operations.

6. Propellant Mass Measurement in Zero Gravity Environment. In any manned space flight mission, it should be possible to determine the quantity of individual propellants on board at any specified time. Thus, a requirement exists for an on-board propellant mass measurement system which is operable in a zero gravity environment. A system has been proposed for application to the orbital tanking mode. This system is then generalized and made applicable to any stage propellant tank.

The proposed concept for determining the mass of propellant within an orbiting space vehicle assumes a nonvented system. The mass of propellant within a vehicle propellant tank can be determined by knowing the total volume and physical properties of the liquid propellant contained therein. By monitoring the pressure and temperature of a known mass of helium gas within the propellant tank, and the pressure and temperature of the propellant, the gas laws may be utilized to determine the propellant mass within the tank. For further information, refer to report No. MIN-LOD-DL-6-62, "Proposal for Determining the Mass of Liquid Propellant Within a Space Vehicle Propellant Tank Subjected to Zero Gravity Environment" by R. L. Evans and J. R. Olivier.

7. Orbital Storage of Liquid Hydrogen. An extensive research study involving the long term storage of liquid hydrogen in space has been completed. A NASA technical note (No. D-559) entitled "Orbital Storage of Liquid Hydrogen" by J. R. Olivier and W. E. Dempster was published in August 1961.

This effort required approximately two man-years in a comprehensive technical study of orbital storage techniques for  $LH_2$  (vented versus nonvented) parameters affecting storage time (insulation properties, stagnant versus agitated fluid conditions, orbital characteristics, tank configurations, et cetera), zero-g venting, insulation precooling, and the uses of shadow shields.

This report presents the influence of various design parameters on the storage time of liquid hydrogen in space. Emphasis was placed on nonvented storage of subcooled liquid hydrogen in a low geocentric orbit (300 n. mi.).

The nonvented storage concept has economical and technological advantages over the vented tank concept. However, for extended nonvented storage periods, the liquid hydrogen must be subcooled prior to launch.

A spherical tank was considered the optimum shape from a heat transfer standpoint. However, this report was based on an 18-foot diameter cylindrical tank with hemispherical bulkheads. This coincides with the diameter of the S-IV stage of the SATURN vehicle.

The calculations to determine storage times were based on the assumption of having stagnant fluid conditions in the orbiting tank in order to obtain conservative results. The calculations further considered the fundamental differences in thermal environment of a

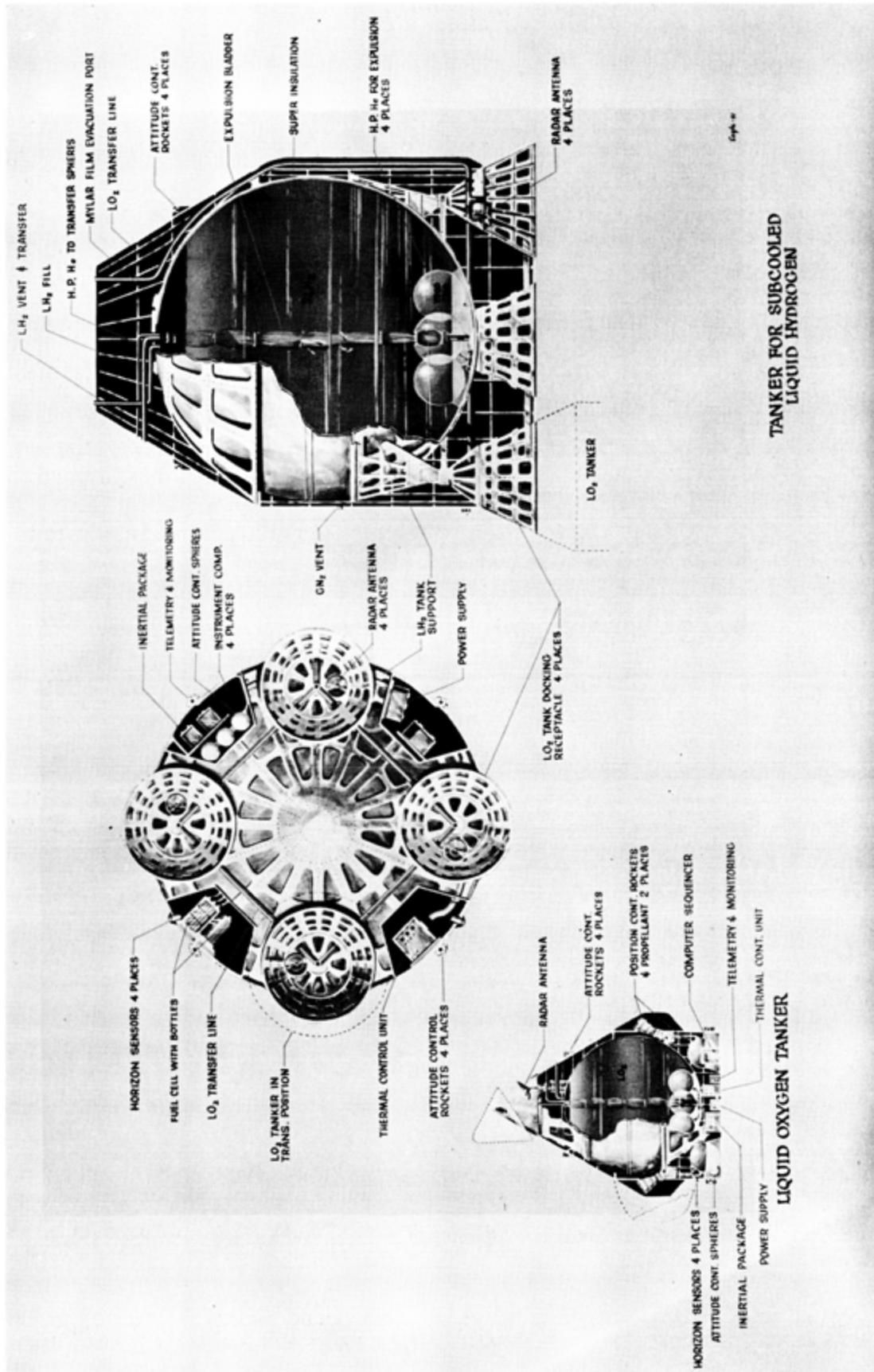

FIGURE 33. CRYOGENIC PROPELLANT TANKERS (ARTIST'S CONCEPT)

vehicle tank, which is an integrated structural element, and an orbital storage tank, which is an individual structure except for the duration of powered flight.

8. Liquid Hydrogen Subcooling Requirements. A preliminary study on this subject was necessitated after reviewing the recommendations and conclusions of the report previously discussed on orbital storage, which cited a requirement for subcooling of liquid hydrogen payloads for orbital operations.

9. Cryogenic Tankers. Detailed design and analysis studies were performed relative to the orbital storage and transfer of liquid oxygen. Tanker design was established after giving primary consideration to vented versus nonvented concepts, tank materials and equilibrium skin temperatures, tank insulations, plumbing requirements, tank support structures, and tank shape factors. Transfer systems were proposed based on a thorough evaluation of expulsion techniques.

10. Lunar Storage of Liquid Propellants. As described in Reports MIN-LOD-DL-1-62 and NASA TN-D-1117, "Lunar Storage of Liquid Propellants," a considerable amount of detailed study effort has been directed by this Branch in all major technical aspects of this problem area. The following abstract of the above report describes the work accomplished.

"Unlike the earth with its attendant atmosphere, the moon is situated in a near vacuum ( $10^{-13}$  earth atmospheres) which produces a thermal environment quite different from that on earth. Thus, the temperature of the lunar surface and objects located thereon depends primarily on the laws and mechanisms of radiation heat transfer. The temperature of the lunar subsurface and foreign bodies contained therein are also influenced by this form of energy transfer, but are primarily affected by conduction heat transfer.

"Radiation equations are set down which show that the temperature of the lunar surface during the daylight period is proportional to the cosine of the angle formed by the sun's rays and a normal to the lunar surface. A geometric relationship is established between this angle and the lunar latitude and lunar time angles. Basically, it shows that the lunar surface temperature decreases with increasing latitude angles; also, the lunar surface temperature is at its maximum at any given latitude at a time angle corresponding to noon.

"The surface temperature of a well-insulated liquid propellant storage tank is then examined in light of this hypothesis. Several parameters were examined to determine their influence in controlling or limiting the tank surface temperature. Parameters investigated include tank surface properties, tank geometry, and locally altering the lunar surface in the vicinity of the tank.

"The heat flux with respect to two classes of propellants (low boiling point and high boiling point), stored above-ground, is discussed. Due to

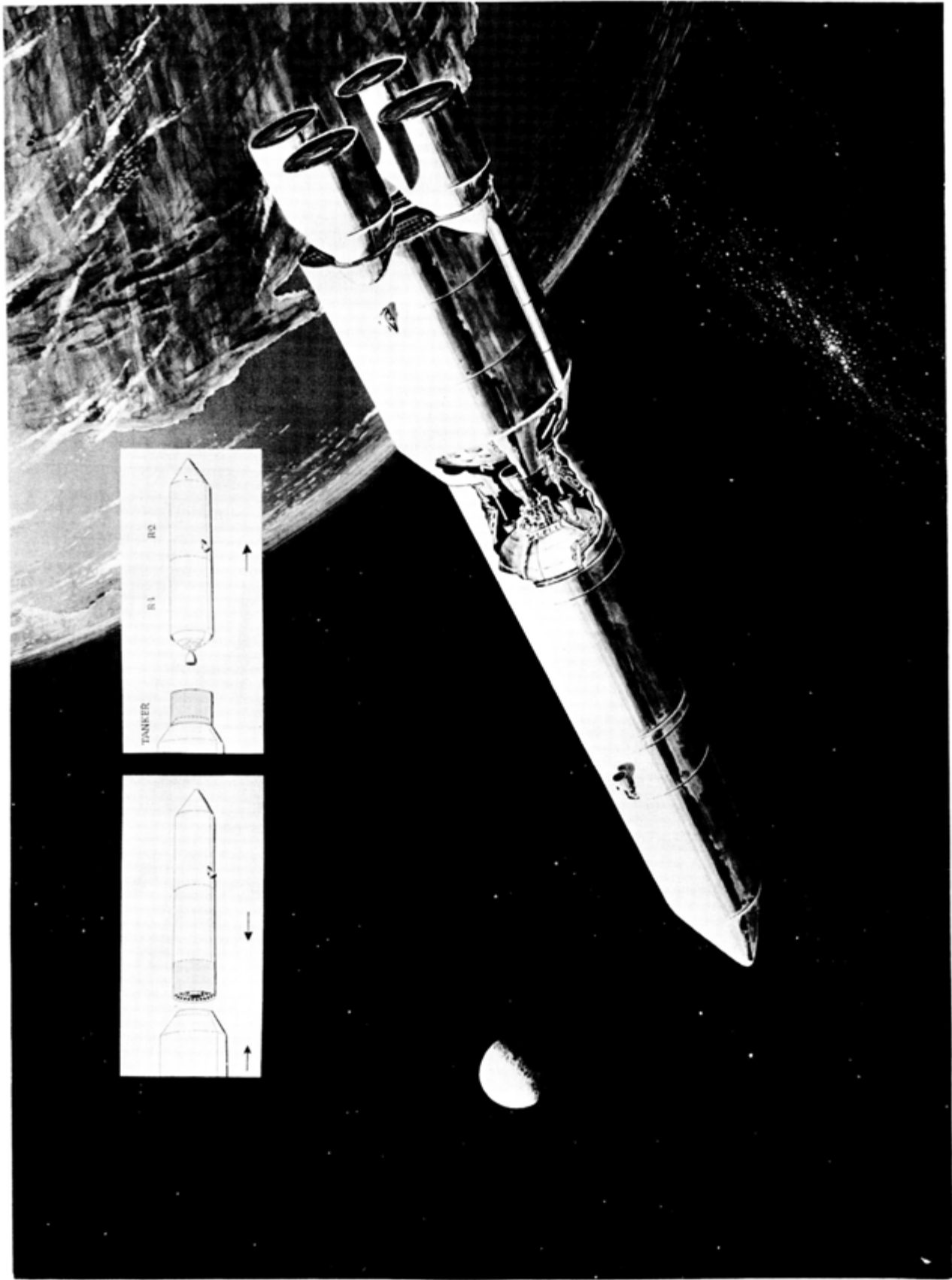

FIGURE 34. REFUELING OPERATIONS IN ORBIT (ARTIST'S CONCEPT) •

the equilibrium temperature of high-boiling point propellants, it is pointed out that the storage period may be indefinite under proper thermal conditions. Low boiling point fuels, on the other hand, may be stored for a finite period only. The most desirable methods for maintaining these propellant classes are presented with respect to latitude location, tank geometry, tank surface properties, and alteration of lunar surface properties.

"The thermal environment of a tank situated beneath the lunar surface is described. Due to the complexities of the problem, the tank surface temperature is assumed to be equal to the lunar subsurface temperature. Subsequently, the heat flux with respect to the stored propellant is discussed.

"In conclusion, a comparison of the storage times attainable for LH<sub>2</sub> storage above-ground and below-ground shows that they can be made almost equal. On this basis, it is seen that factors other than heat transfer decide whether the storage tank should be buried under or placed upon the lunar surface".

#### 11. Feasibility of Monorail Transit Methods and Facilities on the Lunar Surface.

When a permanent lunar basing system is firmly established, it will be necessary to provide some efficient method of transportation between the various components of the complex, or perhaps between lunar bases. This provision might readily be considered as an integral part of the lunar base concept. Effort in fiscal year 1962 was directed toward compilation of data and reference material regarding the feasibility of monorail transit methods and facilities on the lunar surface. Since environmental conditions present an adversity to both mechanical and human mechanisms during lunar surface operations, such a transit system appears to be a simple, stable, and valuable component of future, more complex lunar basing system. Available literature gives little data that might govern mechanical and structural specifications for fabrication and construction on the moon, and immediately reveals that a great deal of effort is still required for development of earth-based monorail systems. Detailed efforts on this project may be restarted at a later date.

#### 12. Hazards Associated with Lunar Landing or Return Operations.

With the advent of lunar landings planned for the near future, it is essential that considerable thought be given to the behavior of jet exhaust in a vacuum under low gravity conditions, especially in relation to the most probable lunar surface conditions. Of primary concern is the motion of lunar surface particles resulting from the impingement of exhaust gases from a lunar landing or takeoff of a space vehicle and the resulting hazards to the vehicle and to both local and distant manned lunar bases or facilities. The combined parameters of low gravity, high vacuum, and high energy exhaust gases result in the displacement of large masses over considerable distances, so that the problem is not merely a localized one. Preliminary studies have been directed specifically toward determination of the trajectories or flight paths of lunar surface particles accelerated by the jet blast from a lunar landing or return vehicle. A range of particle velocities was assumed based on an anticipated effective exhaust gas velocity of 13,250 feet per second for a lox-hydrogen engine. Thus, velocities both above and below those required for escape or orbit from

the lunar surface were considered. Follow-on work to be accomplished will involve analysis aimed at predicting the mass and distribution of particles most likely to be associated with the velocity distribution ranges previously assumed. Determination of the momentum energy coupling relationships between exhaust gases and lunar surface particles of assumed sizes and density will provide a basis for a better estimate of the degree of hazard involved.

Initial study indications are that cratering, large dust clouds, and the ballistics of relatively large lunar surface particles resulting from a lunar landing or return launching may present serious problems in relation to the landing operation, and most definitely can produce hazardous conditions for both distant and surrounding lunar base facilities, equipment, and personnel. For further information, refer to Report No. MIN-LOD-DL-8-62, April 30, 1962, "A Consideration of Lunar Surface Ballistics and the Hazards Associated with Spacecraft Landing or Return Operations," by D. C. Cramblit.

13. Orientation on the Lunar Surface. Upon landing of a manned vehicle on the surface of the moon, it then becomes necessary to establish a reference system, such that an instantaneous bicoordinate "fix" can be established at any desired time. Because of the lack of atmosphere, surface winds, temperature extremes, and exposure to various types of corpuscular radiations, detailed physical mapping or surveying cannot be easily accomplished.

Very precise and reliable methods and equipment will be required, both for lunar surface navigation and for establishing precise launch timetables and takeoff trajectories for a return flight to earth.

Although considerable work has been directed toward determination of lunar trajectories and establishment of space referenced guidance systems during midcourse and terminal flight phase, very little effort has gone into determining the optimum procedures and equipment required for precision navigation and orientation of a vehicle once landed on the lunar surface. Thus, it becomes necessary to establish a precise and reliable space reference system, along with definition of the basic "hardware" operational requirements and preliminary design criteria for use in conjunction with the established reference system. Selection of optimized automated tracking concepts and instrumentation requirements must be established after primary consideration is given to reliability, minimized weight, and operational capability in the extremes of lunar environment.

This Branch performed considerable research into these problems to assist in clearly defining areas requiring future study and development.

14. Lunar Logistics. Effort has been initiated on a mobility analysis study for various modes of lunar transportation. Fundamental modes of locomotion and maneuverability were investigated for various assumed lunar surface models. Final study results included preliminary design data and operational criteria for optimum transportation, construction, and utility vehicle as selected through a detailed analysis of all major parameters such as mobility, maintainability, reliability, minimized weight, simplicity, and controllability.

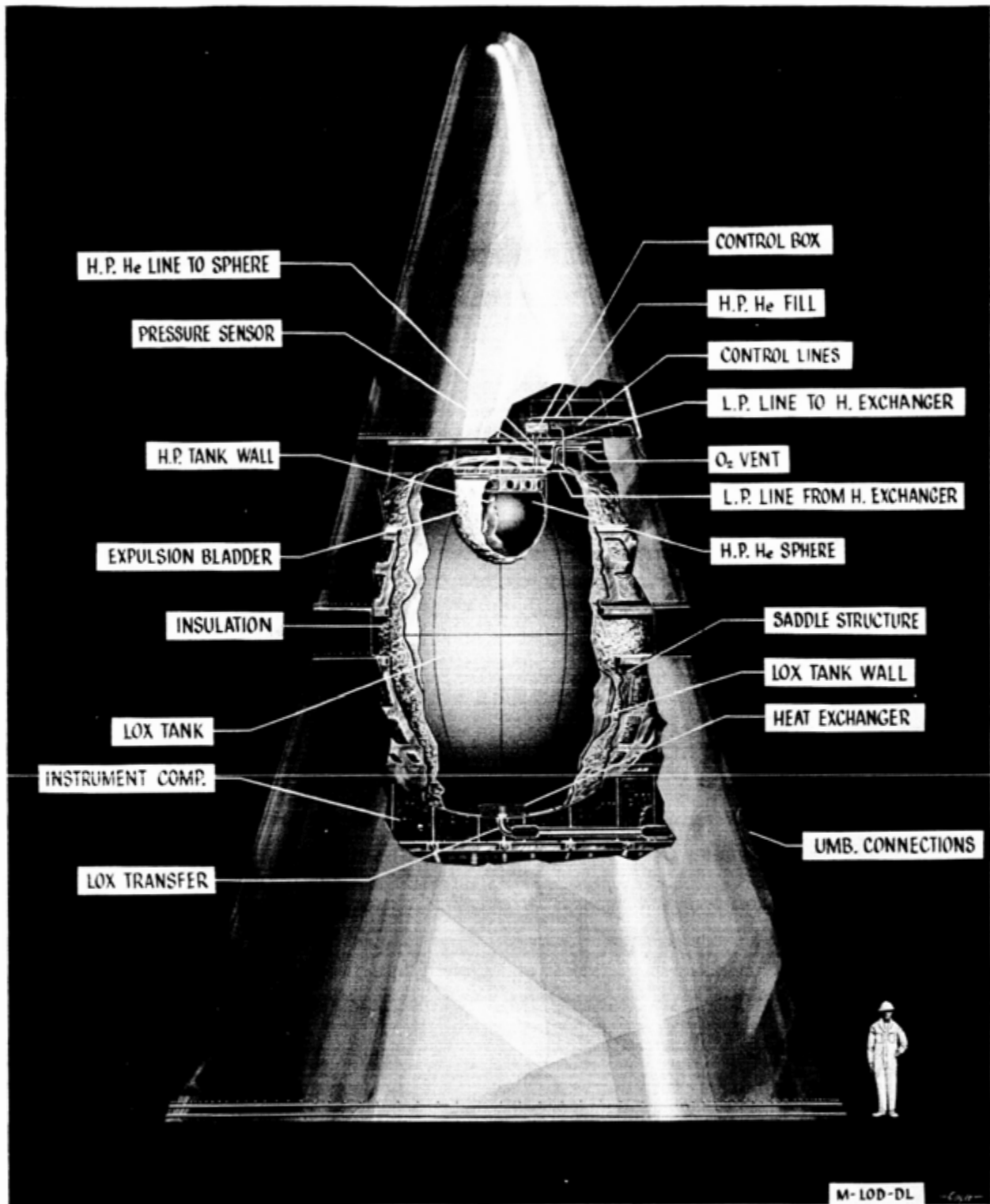
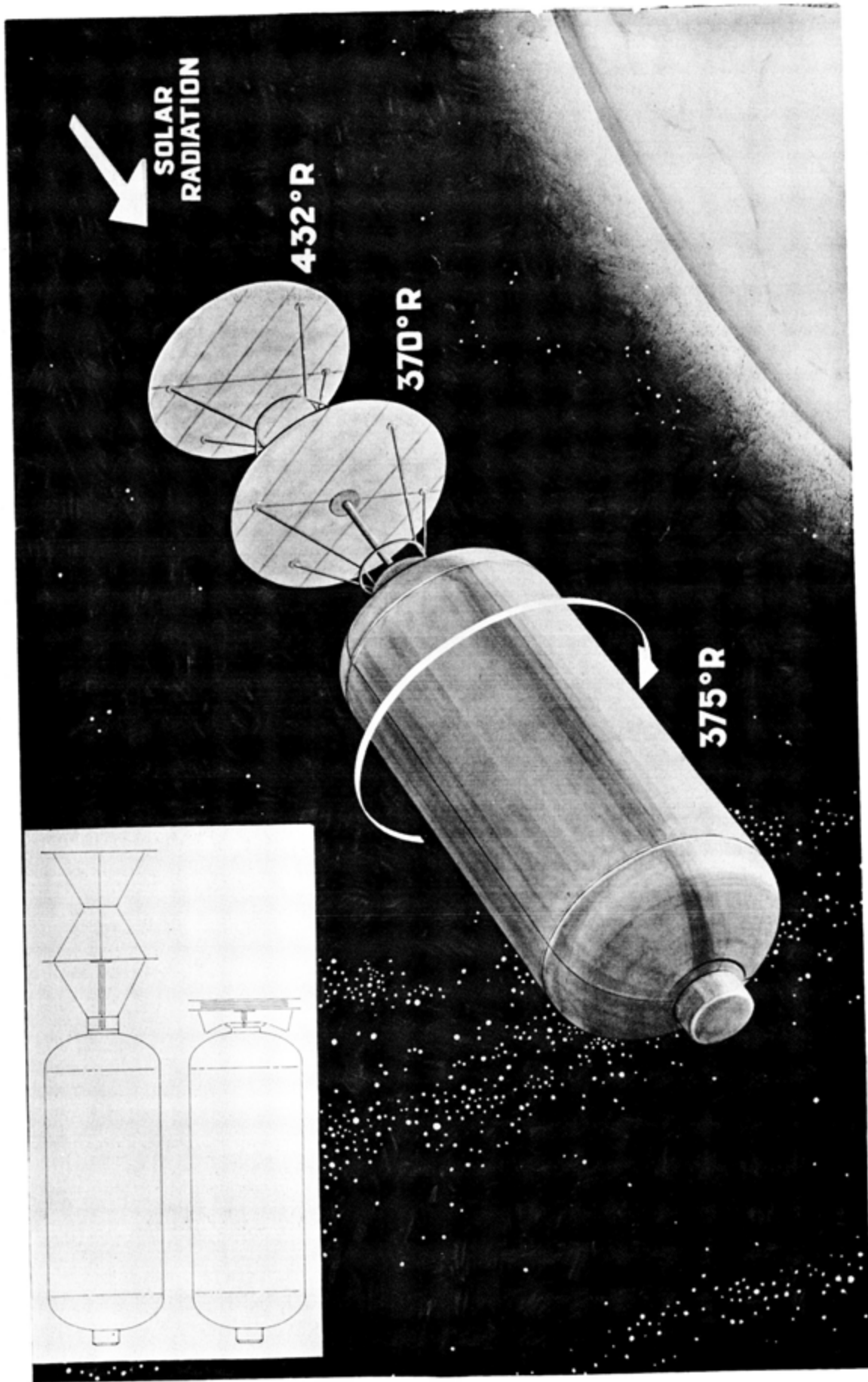

FIGURE 35. LIQUID OXYGEN SPACE TANKER, 200,000-POUND CAPACITY (ARTIST'S CONCEPT)



432° R

370° R

375° R

SOLAR RADIATION

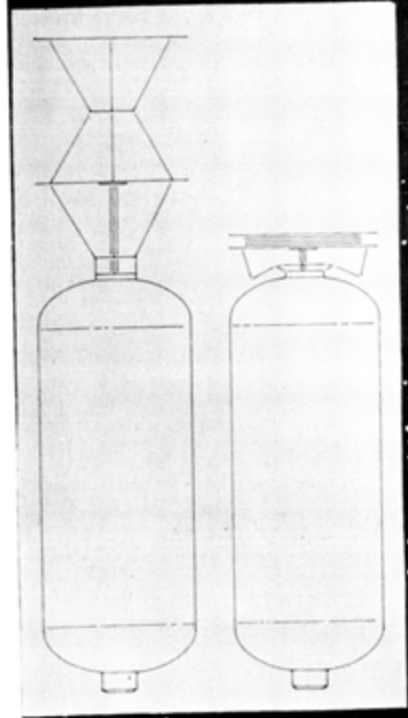

FIGURE 36. ORBITAL PROPELLANT TANK WITH SHADOW SHIELDS (ARTIST'S CONCEPT)



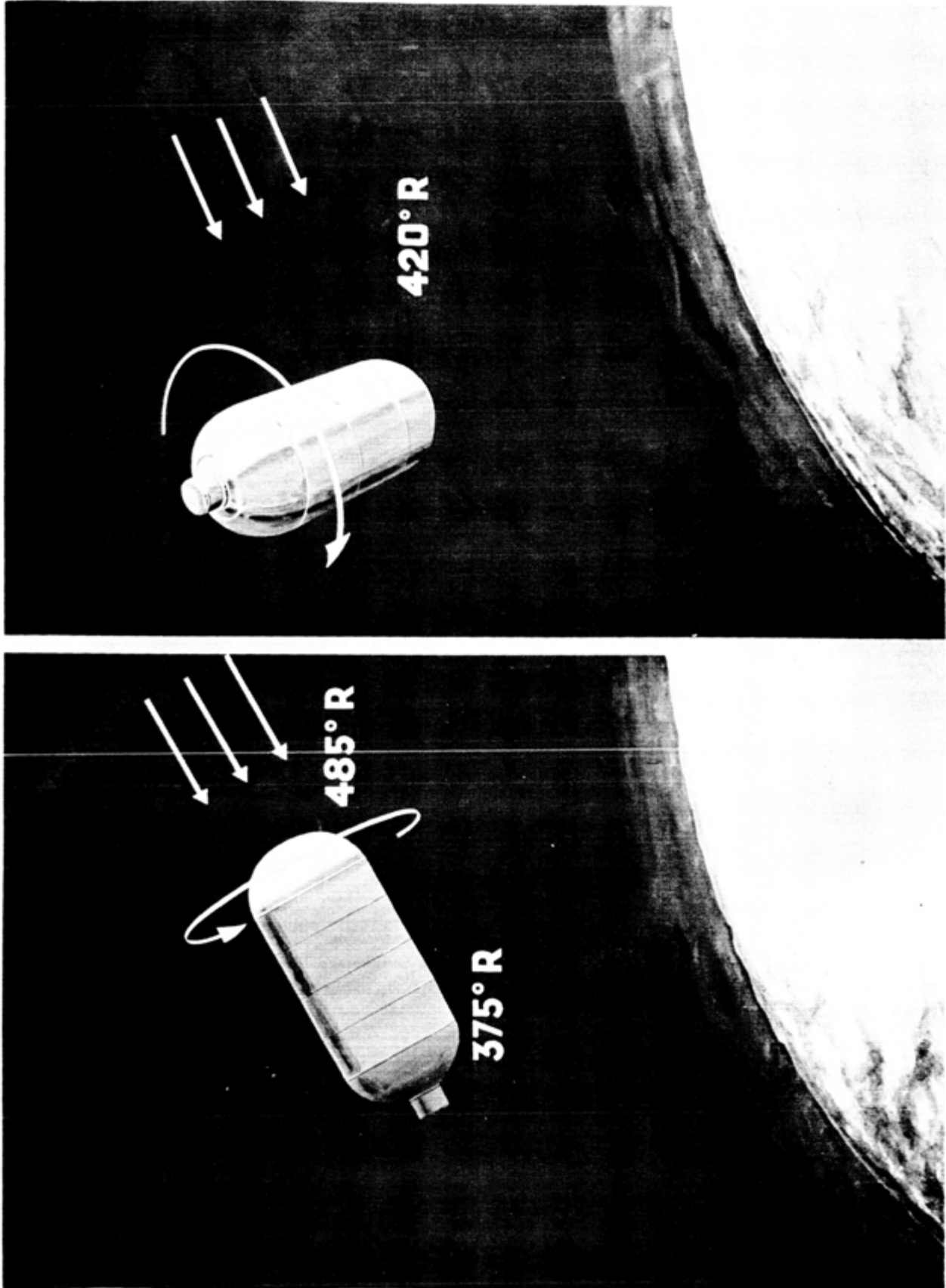

FIGURE 37. ORBITAL PROPELLANT TANKS ORIENTATION (ARTIST'S CONCEPT)

## D. LAUNCH VEHICLE STUDIES.

### 1. Hazards Associated with the Static Testing and Launch of a Nuclear Vehicle.

In conjunction with the efforts to develop a nuclear-powered upper stage for SATURN V, comes the need for the development of test, handling, and launch facilities. Since the field of nuclear technology is a highly specialized one, the major facility development programs will ultimately be accomplished through the efforts of a large number of personnel who are relatively unfamiliar with the requirements of such a program. For this reason, considerable research and study were performed for the purpose of preparing a comprehensive report to familiarize responsible personnel with the general effects of nuclear radiation, presently accepted terminology and definitions, and specifically, with major problem areas to be considered in design of a nuclear launch facility. Radiation effects on general organic and inorganic materials, electronic components, and man were also covered, along with a detailed discussion of these hazards as they specifically apply to launch facilities, components, and operational concepts. For further information, refer to Report No. MTP-LOD-D-61-1, November 17, 1962, "Radiation Hazards Associated with the Testing and Launch of a Nuclear Space Vehicle" by D. C. Cramblit.

2. NOVA Class Solid Vehicles. A member of this office was on the team managing the above study being performed by the Boeing Company. Efforts were directed toward preliminary design of a NOVA class vehicle with emphasis on design analysis of thrust vector control systems, staging concepts, motor clustering, and facility requirements. Detailed layouts of the selected structural concept, layouts of the selected thrust vector control system, reliability analysis, development plans, funding plans, and operations analysis of manufacturing method, fabrication method, ground support equipment, checkout, transportation and launch operational requirements were included in the final study report.

3. C-1 Class Solid Vehicles Utilizing C-1 Launch Facilities. This office provided a member to the management team directing the above contract performed by Lockheed. Advancement in the state of the art of solid propellant motors is rapid in view of recent successes with 100-inch-diameter motors. Thus, NASA feels that it is necessary to investigate the potentials in clustering motors of this size range in development of a solid propellant booster which could replace the present booster of the SATURN I vehicle. This study evaluated such a booster to determine if substantial gains can be attained in SATURN I performance, cost reduction, reliability, and operational considerations.

## E. MISCELLANEOUS STUDIES.

1. Acoustics Study. Considerable in-house effort was directed toward determining the overall sound power levels, transmission characteristics under inversion conditions, and accompanying acoustical hazards associated with the launching of large space vehicles. Following these initial study efforts, a detailed theoretical and actual measurements program was conducted by Bolt, Beranek, and Newman working under a contract directed by this office. This study was conducted in three principle parts. Part I involved estimation of the noise and vibration field of future large boosters based

on available data, analysis of typical long-range sound propagation and meteorological conditions for coastal, overwater, and inland launch sites, and formulation of appropriate acoustical design criteria applicable to personnel, critical launching equipment, building structures, and residential communities. Part II was initiated to verify the estimates of Part I with the aid of measurements on the F-1 engine test firings and during SATURN launch. Part III involved further analysis of the mechanical and vibration fields of large boosters based on available meteorological data for the Cape Canaveral area.

2. Inputs to the DYNA-SOAR Program. With the possibility of using the SATURN as a booster for the Dyna-Soar vehicle, it became necessary to determine the impact of such a configuration on existing ground support equipment and launch facilities, the extent and cost of necessary modifications, and the capability of the system in handling such a payload. This Branch analyzed the overall requirements for this program, and directed the efforts of project engineers within LOC who were given assignments for detailed treatment of specific problem areas. All this information was collected, collated, published, and transmitted to the Cape for further action.

3. Commercial Satellite Programs. Periodically, the initiation of a new program places the requirement for preliminary cost analysis and concept planning on this office, which completed an annual and total cost estimate for ground support equipment and facilities to support the Commercial Satellite Program.

4. Cosmic and Solar Flare Radiation. Investigation of cosmic and solar flare radiation has been conducted in an effort to establish shielding requirements and design criteria for manned space operations. Occurrence probability of high- and low-energy flares, location of the orbit with respect to the earth's geomagnetic equator, anticipated flight duration, relative biological effectiveness (RBE) of solar protons, and maximum integrated whole body radiation doses to be allowed for space operations were some of the parameters investigated in this preliminary study.

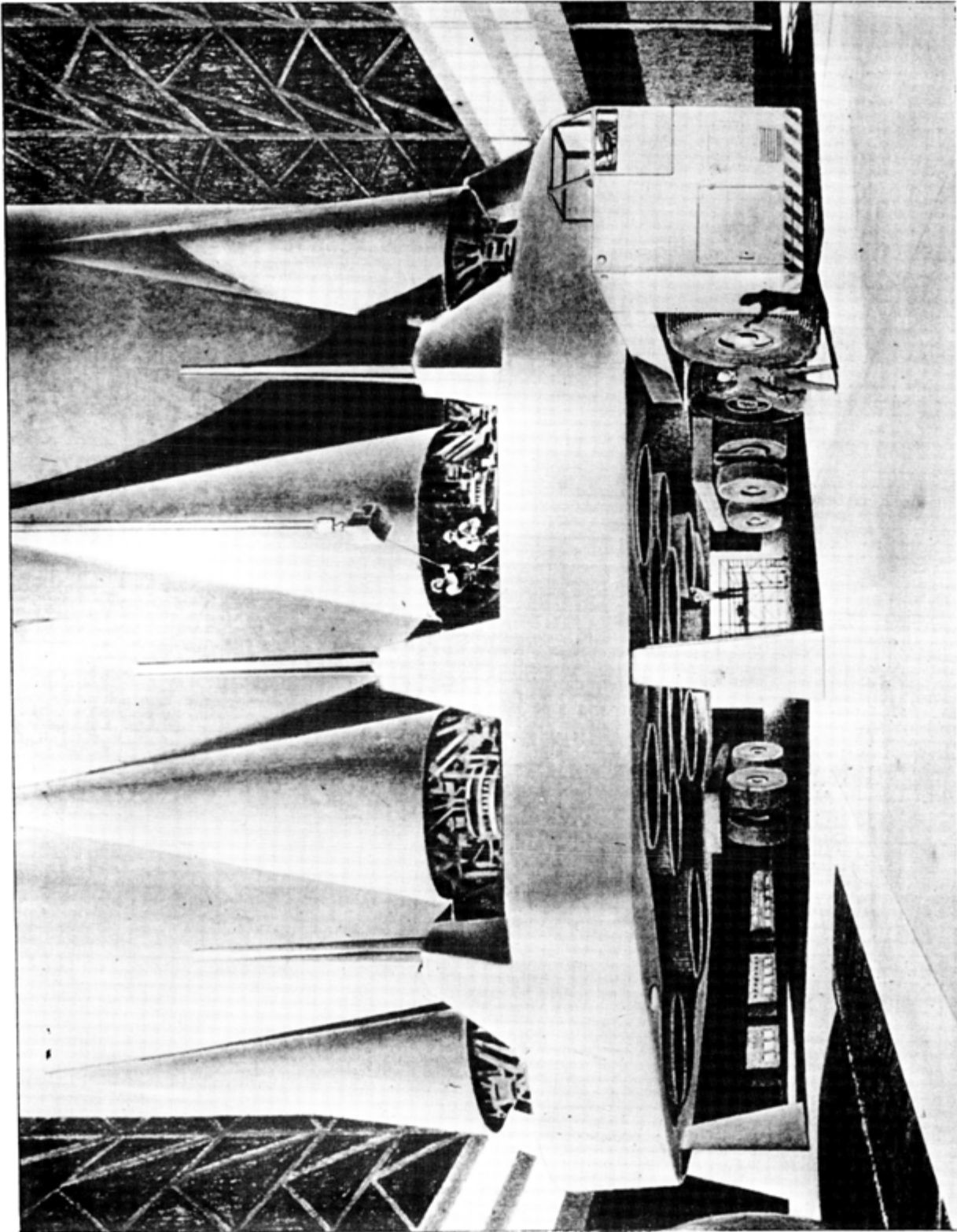

FIGURE 38. NOVA ENGINE CHECKOUT AREA (ARTIST'S CONCEPT)

## SECTION XIV CURRENT SUPPORT ON MSFC-CONTRACTED STUDIES

A member(s) of the Future Studies Branch is serving on the management team of each MSFC study contract listed below. Often such membership requires that the party perform complementary, educational in-house studies to provide effective guidance for, and to evaluate the contracted study.

### A. NOVA VEHICLE SYSTEMS STUDIES.

The Martin Company and General Dynamics/Astronautics are currently performing studies on a NOVA-class vehicle system capable of placing 1,000,000-pound payloads into low orbit or 400,000-pound payloads to escape with the best attainable reliability utilizing state-of-the-art hardware for the time frame around 1975-78. Both solid and liquid propellant systems are to be considered. The current study may be called a pre-development phase, which is required to more clearly define the desired NOVA vehicle configuration prior to initiating a development program. Major objectives of this study will be to optimize launch vehicle system design and sizing, optimize fabrication techniques, and to determine the best methods for achieving "man-rating" with reasonable cost and within a reasonable length of time.

### B. POST-NOVA LAUNCH VEHICLE STUDY.

This study was initiated to review the anticipated state of the art for very large launch vehicles of the 1974-75 time period. This vehicle is to be considered in the one-million-pound payload class, although a two-million-pound payload class will not be ruled out. Of primary importance in this study is the development of a vehicle concept that will result in specific operating transportation costs of \$25 to \$50 per pound of payload (not including cost of launch facility operations, etc.). This may be compared with current SATURN I costs of \$150 per pound of payload. Since \$100 per pound seems to be the lower limit for expendable vehicles, the Post-NOVA must be developed for recovery. Liquid, solid, and nuclear propulsion (and combinations thereof) will be considered in these conceptual studies now being performed by Rand, General Dynamics, and Douglas.

### C. TEN-TON REUSABLE BOOSTER.

The objectives of this study are to define launch vehicle systems to lift 10 tons to and from earth orbit in a 1973 time period. This vehicle may eventually be used as cargo supply carrier for an earth-orbiting space station. Lockheed and North American are the contractors for this study.

#### D. REUSABLE GROUND LAUNCH VEHICLE, 50- TO 100-TON ORBITAL PAYLOAD CLASS.

Considering the SATURN V is established as the major support vehicle for orbital launchings in the 1965-70 time period, this study being performed by Boeing and North American Aviation is intended to establish the conditions under which a reusable configuration would be advantageous, the configurations best suited to succeed the SATURN V, and a plan for the orderly development of the technology and techniques necessary for vehicle reuse.

#### E. ADVANCED LUNAR TRANSPORTATION.

In addition to the manned lunar landing program, emphasis must now be placed on transportation of large cargoes to the lunar surface. Present systems cannot be economically utilized for this application; therefore, more economically attractive systems are being investigated by Lockheed, Chance-Vought, and Martin, utilizing technology from SATURN, RIFT, APOLLO, and other systems. This study is being performed to investigate and compare two possible approaches for a more attractive follow-on lunar transportation system. One approach utilizes a SATURN V with an expendable RIFT-type nuclear third stage used to boost a payload to a lunar orbit. From this lunar orbit, the payload is soft-landed on the lunar surface with a fourth stage, which has the capability for return launching of a manned payload when required. The second approach utilizes an orbit-launched nuclear vehicle and orbital operations techniques. This reusable nuclear vehicle is used as a ferry vehicle between earth and lunar orbits.

#### F. CRYOGENIC INSULATION INTEGRATION.

This study will develop practical methods for installation of advanced cryogenic insulations and insulating materials into containers which will be subjected to space storage of cryogenic propellants for periods of four days to several weeks. It will be necessary to evaluate and establish environmental parameters upon which the design will be based and tested.

#### G. NUCLEAR LUNAR LOGISTICS SYSTEM.

This study will examine the application of various nuclear devices for developing the lunar logistics system. Lockheed is performing the out-of-house work on this study.

#### H. NUCLEAR FLIGHT SAFETY STUDY.

Lockheed is performing a study for MSFC to determine the hazards of and procedures for handling the launch and flight of a nuclear-powered vehicle. The results of this study will be incorporated into the overall nuclear space flight system program.

#### I. EARLY MANNED INTERPLANETARY MISSIONS.

This study is being performed by Ford, Lockheed, and General Dynamics, and

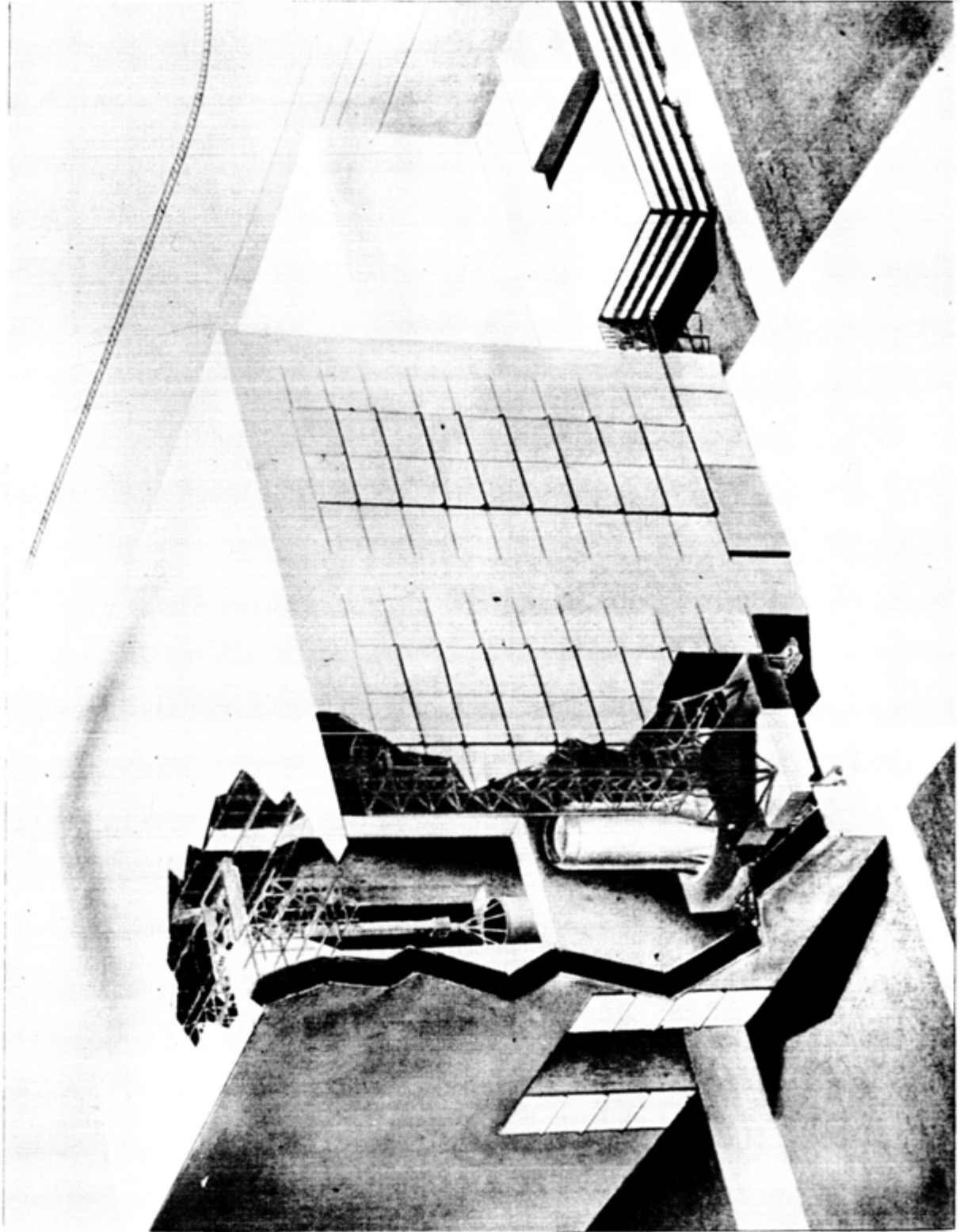

FIGURE 39. NOVA VERTICAL ASSEMBLY BUILDING (ARTIST'S CONCEPT)

involves analysis of a 1970-72 manned mission to Mars or Venus. The nonstop fly-by appears very attractive for this mission. This study should provide a complete detailed mission analysis and information in the following typical problem areas: orbital operational requirements, nuclear propulsion requirements, manning requirements, major subsystem requirements, earth-return modes, trajectory and guidance considerations, life support systems, funding and program plans, vehicle ecologic systems, and environmental protection systems.

Dual planet fly-by missions of the Crocco and Symmetric trajectory classes are to be investigated. The Crocco mission with an August, 1971 launch window requires approximately 400 days. The Symmetric mission with a July, 1970 launch window takes approximately 630 days. Additional results of the trajectory studies and abort trajectories are to be reported. The guidance and navigation subsystem, midcourse corrections, and planetary approach corrections are studied.

The various technological areas required for design criteria will be developed, and several spacecraft designs are to be considered. The all-chemical propulsion Crocco system was discarded due to weight, complexity, and cost. The nuclear-injected Crocco was treated in a similar manner. The lower energy injection for the Symmetric mission leads to the feasibility of a nuclear-injected vehicle with an earth orbit weight of about 400,000 pounds before interplanetary transit.

Mission success probabilities will be presented for the various missions considered and for SATURN V, NOVA, and Super-NOVA earth launch vehicles in light of possible development.

#### J. MANNED MARS EXPLORATION IN THE UNFAVORABLE TIME PERIOD.

The prime objective of this study is to survey all attractive mission profiles for manned Mars missions during the 1975-85 time period. The main criterion of optimization is to minimize initial mass in earth orbit.

#### K. FLUID TRANSFER AT LOW "G".

This Branch has performed considerable past work on storage of cryogenic propellants in orbit, and made suggestions on the methods of refueling orbiting space vehicles. An MSFC study will be contracted for a concerted comprehensive examination of techniques for filling and emptying orbiting tanks in preparation for later lunar and Mars missions. The study will theoretically predict the shape of the propellant free surface within the discharge tank during transfer of liquid propellant. Primary interest is in the surface shape when the pressurizing gas first reaches the transfer line.

#### L. SOLIDS SAFETY HANDBOOK STUDY.

The objectives of this program are to develop preliminary launch concepts to use as a base guideline and to establish the following standards: solid propellant safety handling procedures and standards that may be integrated into operational analysis when



solid launch facilities are required. The results will define critical areas of handling, testing, and launch of solid propellant vehicles, and indicate the most desired approach for safety of personnel and equipment.

#### M. COST MODEL FOR LAUNCH VEHICLE.

This study will attempt to organize standardized costing methods for use in analysis of future launch vehicle systems. All proposed alternate launch vehicle systems must be compared using a common costing technique to arrive at a true optimized cost system. General Dynamics and Martin/Denver are participating in this effort.

APPROVAL

TR-4-17-3-D

FUTURE STUDIES BRANCH  
ACTIVITIES REPORT  
FISCAL YEAR 1963

  
Georg von Tiesenhausen  
Chief, Future Studies Branch

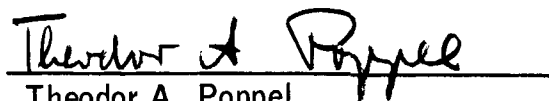
  
Theodor A. Poppel  
Director, Launch Support Equipment  
Engineering Division